



KINETICS® FH

FIBERGLASS ISOLATION HANGER

Fiberglass is suitable for use in high temperature spaces such as mechanical equipment rooms and outdoor applications where there is a fluctuation in temperature.

Application

Kinetics FH fiberglass hangers are recommended for use in isolating high frequency noise and vibration produced by suspended mechanical or electrical equipment, piping, and ductwork, in the ceiling areas of high temperature locations. Suitable for use indoors and outdoors.

High sound transmission loss ceiling systems can be effectively isolated by FH hangers. When isolating sources of predominately low frequency energy, Kinetics SFH hangers are recommended.

Description

Model FH Hangers incorporate a coded, molded, inorganic fiberglass isolation pad attached to a steel load transfer plate and to a stamped or welded hanger bracket. Hangers will allow a support rod misalignment through a 30° arc. Isolation brackets will carry 500% overload without failure. Fiberglass

pads are fine (0.00027" diameter/6.8 microns) bonded annealed glass fibers which are stabilized by severely overloading the material during the manufacturing process, and then coated with a flexible moisture-impervious elastomeric membrane. Fiberglass is unique in that the natural frequency is constant over a wide operating load range, and the stiffness increases proportionately with load applied.

Unlike neoprene-based pad hangers, fiberglass pads are suitable for use in high temperature applications, making them a better isolation material for use in mechanical rooms. Model FH Hangers are available in sizes with capacities from 40 to 1600 lbs. (18 to 726 kg), with deflection of 0.14" to 0.34" (4 to 9 mm).

Kinetics FH hangers are shipped fully assembled and ready for installation in threaded rod suspension systems.

STANDARD RATINGS						DIMENSIONS									
HANGER TYPE	PAD DENSITY	LOAD		DEFLECTION		L		W		A		H		D _{MAX}	
		lbs	kg	in	mm	in	mm	in	mm	in	mm	in	mm		
FH-40	G	40	18	0.31	9	3.97	101	2.15	55	1.50	30	1.20	30	0.38	10
FH-80	L	80	36	0.24	7	3.97	101	2.15	55	1.50	30	1.20	30	0.38	10
FH-160	Q	160	73	0.17	5	3.97	101	2.15	55	1.50	30	1.20	30	0.38	10
FH-290	QR	290	132	0.14	4	3.97	101	2.15	55	1.50	30	1.20	30	0.38	10
FH-200	G	200	91	0.34	8	5.09	129	3.77	96	3.00	76	1.52	39	0.63	16
FH-400	L	400	181	0.26	6	5.09	129	3.77	96	3.00	76	1.52	39	0.63	16
FH-800	Q	800	363	0.18	4	5.09	129	3.77	96	3.00	76	1.52	39	0.63	16
FH-1600	QR	1600	726	0.16	4	5.09	129	3.77	96	3.00	76	1.52	39	0.63	16

Specifications

Vibration isolators with maximum static deflection requirements under the operating load conditions not exceeding 0.34" (9 mm) shall be hangers consisting of a precompressed molded fiberglass insert, complete with load transfer plate and assembled in a stamped or welded steel bracket.

The fiberglass insert shall be individually coated with a flexible, moisture-impervious elastomeric membrane. The insert shall be molded from glass fibers with fiber diameters not exceeding 0.00027" (6.8 microns) and with a modulus of elasticity of 10.5 million PSI (738,223 kg/cm²).

The fiberglass insert is non-corrosive, non-combustible, non-absorbent, and resists rust, ozone, mildew and fungus. It is vermin proof, will not shrink, swell, or decompose. Isolation characteristics of the fiberglass insert are constant over a temperature range of -40°F to 250°F (-40°C to 121°C).

Natural frequency of fiberglass vibration isolators shall be essentially constant for the operating load range of the supported equipment. Vibration isolators shall be coded to indicate load capacity.

The hanger bracket shall be designed to carry a 500% overload without failure and to allow a support rod misalignment through a 30° arc without metal-to-metal contact or other short circuit.

Isolation hangers shall be selected by the manufacturer for each specific application to comply with deflection requirements as shown on the Vibration Isolation Schedule or as indicated on the project documents.

Vibration isolation assembly shall be model FH, as manufactured by Kinetics Noise Control, Inc.

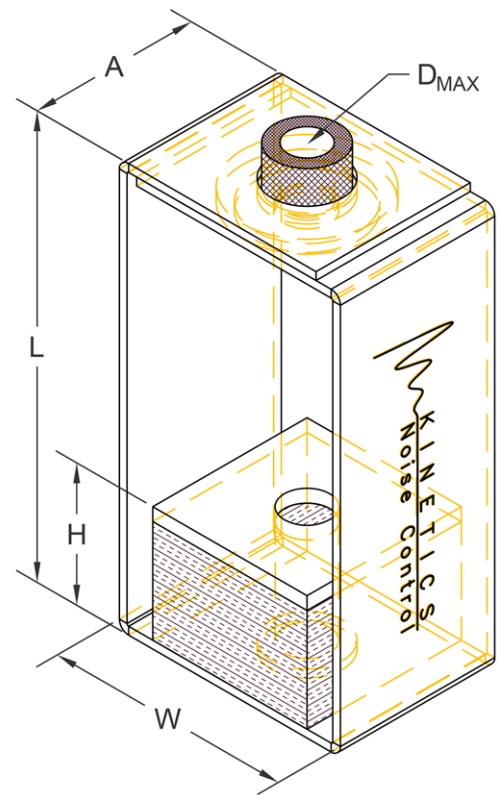

kineticsnoise.com
sales@kineticsnoise.com
1-800-959-1229