

# KINETICS™

Special  
Non-Leveling  
Mounts  
**Model SN**

## Description

Model SN Mounts are custom designed for each application, and are most frequently used to isolate shock produced by large punch presses where the load requirement exceeds the capacity of standard Model KLM mounts. SN mounts can be designed to isolate equipment operating at up to 600 strokes per minute, and with foot bearing loads up to 1000 psi (69 bar).

Model SN mounts incorporate Kinetics high density precompressed molded fiber glass isolation pads or Kinetics Flexoply/Flexco pads bonded to a steel load plate and sized to match the feet of the supported equipment. In cases where the unit loading exceeds the capacity of the isolator, the steel plate can extend beyond the feet to reduce the loading. For uneven floors, or to level the equipment, full size shims should be used between the Model SN mounts and the equipment feet. It is accepted practice on smaller machines to bolt the SN load plate to the equipment foot.

In isolating large presses, it is advisable to use an anchor bolt into the floor, which is isolated from the equipment foot with a fiberglass washer.



## Specifications

Shock isolators shall be precompressed molded fiber glass pads individually coated with a flexible, moisture-impervious elastomeric membrane. Vibration isolation pads shall be molded from glass fibers with fiber diameters not exceeding 0.00027 in (6.8 microns) and with a modulus of elasticity of 10.5 million PSI (738,223 kg/sq. cm).

Natural frequency of fiber glass shock isolators shall be essentially constant for the operating load range of the supported equipment. Shock isolators shall be bonded to a heavy steel load transfer plate which includes a hole or holes to permit lag-down. Isolators shall also include a fiber glass isolation washer to prevent short-circuiting. Shock isolators shall be selected by the manufacturer for each specific application to achieve the desired reduction of shock energy. Shock isolators shall be Model SN as manufactured by Kinetics Noise Control, Inc.

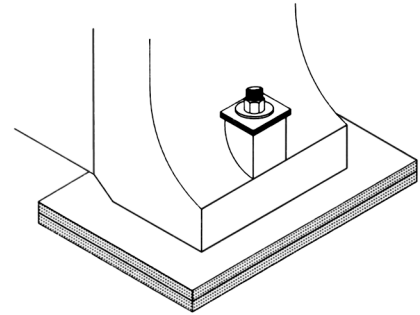

Isolation Material	Recommended Maximum Load		Normal Equipment Operating Speed for Good Shock Isolation for Standard Pad Thickness, Strokes per Minute	
	PSI	Bars	1 in (25 mm) Pad	1/2 in (13 mm) Pad
Type Q Fiber glass	50	3.4	up to 150	151-250
Type R Fiber glass	75	5.1	up to 250	251-350
Type S Fiber glass	100	6.9	up to 250	251-600
Type NDM Flexco	500	34.0	up to 300	300-600
Type NDF Neoprene	1000	68.9	up to 350	351-600



kineticsnoise.com  
 sales@kineticsnoise.com  
 1-800-959-1229