

KINETICS™

1" and 2" Deflection Isolation Hangers Model SRH

- Polyester Powder Coated Bracket and Spring Coil
- Self-Centering Cap Patent No. 5,653,426

Application

Kinetics Model SRH hangers are used to isolate suspended sources of both noise and vibration. Suspended mechanical equipment such as in-line fans, cabinet fans, and piping and ductwork in close proximity to mechanical equipment are typical uses of Model SRH hangers featuring the patented **No-Short self-centering cap**.

Kinetics' minimum recommendation for the placement of spring hangers is that they be installed on all piping in the equipment room and on the first 50' (15 m) for piping that extends outside of the equipment room. For typical installations, the three spring hangers closest to the equipment should have equal deflection to the equipment isolators. The remaining spring hangers should have a minimum deflection of 1" (25 mm). In noise sensitive areas, the pipe hangers selected should have the same deflection as that specified for the equipment isolation and all piping in the building should be isolated.

High sound transmission loss ceiling systems can be isolated by the use of SRH hangers in the ceiling suspension system.

Standard SRH hangers are shipped fully assembled and ready for installation in threaded metal rod suspension systems.

Model SRH hangers are available in a wide range of load and static deflection selections and can be provided with labor-saving accessories for adaption to wire or strap suspension systems, and spring may be preloaded for ease in erecting piping at a fixed elevation.



Description

Kinetics SRH vibration isolation hangers consist of free-standing, large diameter, laterally stable steel springs in series with an elastomer-in shear insert, assembled into a stamped or welded hanger bracket. To assure stability, the spring element has a minimum lateral spring stiffness of 1.0 times the rated vertical stiffness. Hangers with properly deflected coils will allow a support rod misalignment through a 30° arc without short circuiting. Isolation brackets will carry a 500% overload without failure. Hangers are available in deflections from 1.20" to 2.40" (30 to 61 mm), and in capacities from 35 to 3500 lbs. (16 to 1588 kg). Model SRH hangers are superior to hangers which incorporate only springs, which can transmit noise through the all metal construction, and hangers which incorporate only pads, which can transmit low frequency vibration. Kinetics Model SRH hangers are recommended for the isolation of vibration produced by suspended mechanical equipment, low-speed suspended fans, transformers, ductwork, piping, etc.

How the self centering no short cap works:

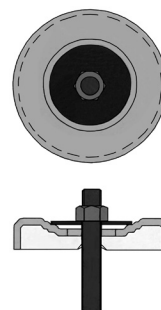

Indexed steps in spring cap correspond to standard washer diameters for the appropriate rod diameter. The washer and rod stay centered in the cap.

Specifications

Vibration isolators for suspended equipment with minimum static deflection requirement exceeding 0.4" (10 mm), and where both high and low frequency vibrations are to be isolated, shall be hangers consisting of a laterally stable spring in series with an elastomer-in-shear insert complete with load transfer plates and assembled in a stamped or welded steel bracket.

The bracket shall be finished with an polyester-based powder coating. The manufacturer shall provide independent laboratory testing showing that the bracket with this finish has endured a minimum of 1,000 hours of exposure to salt spray fog testing per ASTM B117 without signs of corrosion.

The elastomer insert shall be molded from oil-resistant compounds and shall be color coded to indicate load capacity and selected to operate within its published load range.

The spring element shall have a minimum lateral stiffness of 1.0 times the rated vertical stiffness.

Springs shall be color coded or otherwise identified to indicate load capacity.

The hanger bracket shall be designed to carry a 500% overload without failure and to allow a support rod misalignment through a 30° arc without metal-to-metal contact or other short circuit.

The hanger bracket shall incorporate spring caps with indexed steps which correspond to the washer diameter of the appropriately sized hanger rod to keep the rod centered in the spring cap and reduce rod misalignment.

Isolation hangers shall be selected by the manufacturer for each specific application to comply with deflection requirements as shown on the Vibration Isolation Schedule or as indicated on the project documents.

The combination isolation hanger assembly with neoprene insert shall be Model SRH, as manufactured by Kinetics Noise Control, Inc.

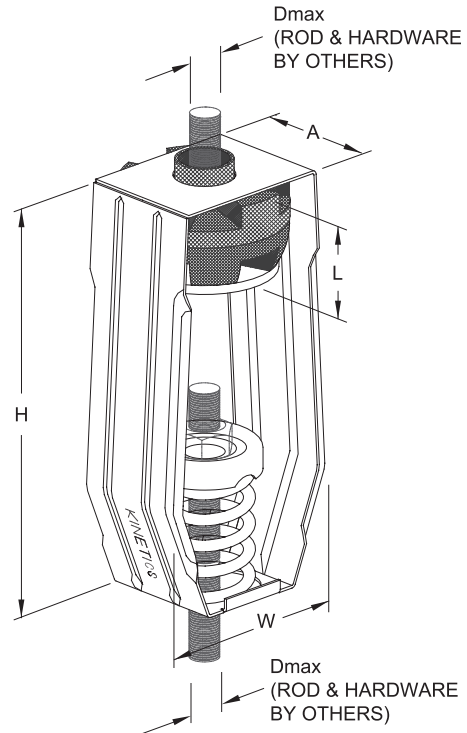

Hanger Type	Spring Color	Standard Ratings						Dimensions									
		Spring O.D.		Load		Deflection		L		H		W		A		Dmax	
		in	mm	lbs	kg	in	mm	in	mm	in	mm	in	mm	in	mm	in	mm
SRH-1-35	Blue	1.75	44	35	16	1.61	41	1.72	44	7.38	187	3.69	94	2.25	57	0.63	16
SRH-1-70	Green	1.75	44	70	32	1.55	39	1.72	44	7.38	187	3.69	94	2.25	57	0.63	16
SRH-1-125	Gray	1.75	44	125	57	1.56	40	1.72	44	7.38	187	3.69	94	2.25	57	0.63	16
SRH-1-245	Brown	1.75	44	245	111	1.52	39	1.72	44	7.38	187	3.69	94	2.25	57	0.63	16
SRH-1-370	Orange	1.75	44	370	168	1.29	33	1.72	44	7.38	187	3.69	94	2.25	57	0.63	16
SRH-1-500	Beige	1.75	44	500	227	1.45	37	1.89	48	7.38	187	3.69	94	2.25	57	0.63	16
SRH-1-600	Chrome	1.75	44	600	272	1.35	34	1.89	48	7.38	187	3.69	94	2.25	57	0.63	16
SRH-1-700	Beige/Wht	1.75	44	700	318	1.40	36	1.89	48	7.38	187	3.69	94	2.25	57	0.63	16
SRH-1-805	Chrm/Wht	1.75	44	805	365	1.25	32	1.89	48	7.38	187	3.69	94	2.25	57	0.63	16
SRH-1-150	Beige	3.00	76	50	23	1.13	29	2.00	51	8.59	218	5.58	142	3.63	92	0.88	22
SRH-1-100	Chrome	3.00	76	100	45	1.19	30	2.00	51	8.59	218	5.58	142	3.63	92	0.88	22
SRH-1-250	Blue	3.00	76	250	113	2.12	54	2.00	51	8.59	218	5.58	142	3.63	92	0.88	22
SRH-1-450	Green	3.00	76	450	204	1.94	49	2.00	51	8.59	218	5.58	142	3.63	92	0.88	22
SRH-1-625	Black	3.00	76	625	283	1.80	46	2.00	51	8.59	218	5.58	142	3.63	92	0.88	22
SRH-1-800	Gray	3.00	76	800	363	1.55	37	2.00	51	8.59	218	5.58	142	3.63	92	0.88	22
SRH-1-1000	Red	3.00	76	1000	454	1.45	37	2.00	51	8.59	218	5.58	142	3.63	92	0.88	22
SRH-1-1250	Brown	3.00	76	1250	567	1.38	35	2.00	51	8.59	218	5.58	142	3.63	92	0.88	22
SRH-1-1700	Orange	3.00	76	1700	771	1.35	34	2.00	51	8.59	218	5.58	142	3.63	92	0.88	22
SRH-1-2200	Org/Gray	3.00	76	2200	998	1.52	39	1.85	47	9.50	241	5.00	127	4.75	121	0.88	22
SRH-1-2465	Blue	3.00	76	2465	1118	1.58	40	1.85	47	9.50	241	5.00	127	4.75	121	0.88	22
SRH-1-2865	Blue/Gry	3.00	76	2865	1300	1.67	43	1.85	47	9.50	241	5.00	127	4.75	121	0.88	22
SRH-1-3500	Blue/Brn	3.00	76	3500	1588	1.82	46	1.85	47	9.50	241	5.00	127	4.75	121	0.88	22
SRH-2-35	Blue	1.75	44	35	16	2.09	53	1.72	44	7.38	187	3.69	94	2.25	57	0.50	13
SRH-2-70	Green	1.75	44	70	32	2.19	56	1.72	44	7.38	187	3.69	94	2.25	57	0.50	13
SRH-2-120	Gray	1.75	44	120	54	2.32	59	1.72	44	7.38	187	3.69	94	2.25	57	0.50	13
SRH-2-220	Brown	1.75	44	220	100	2.29	58	1.72	44	7.38	187	3.69	94	2.25	57	0.50	13
SRH-2-260	Blue	3.00	76	260	118	2.21	56	1.75	44	8.59	218	5.58	142	3.63	92	0.88	22
SRH-2-465	Green	3.00	76	465	211	2.01	51	1.75	44	8.59	218	5.58	142	3.63	92	0.88	22
SRH-2-720	Black	3.00	76	720	327	2.08	53	1.75	44	8.59	218	5.58	142	3.63	92	0.88	22
SRH-2-850	White	3.00	76	850	386	1.97	50	1.75	44	8.59	218	5.58	142	3.63	92	0.88	22
SRH-2-1025	Beige	3.00	76	1025	465	1.99	51	1.75	44	8.59	218	5.58	142	3.63	92	0.88	22
SRH-2-1200	Chrome	3.00	76	1200	544	2.00	51	1.75	44	8.59	218	5.58	142	3.63	92	0.88	22
SRH-2-2000	Orange	5.00	127	2000	909	2.08	53	1.75	44	12.00	305	6.00	152	6.00	152	1.00	25
SRH-2-2500	Blue	5.00	127	2500	1136	2.10	53	1.75	44	12.00	305	6.00	152	6.00	152	1.00	25
SRH-2-2750	Blu/Blu	5.00	127	2750	1250	2.12	54	1.75	44	12.00	305	6.00	152	6.00	152	1.00	25
SRH-2-3025	Blu/Grn	5.00	127	3025	1375	2.14	54	1.75	44	12.00	305	6.00	152	6.00	152	1.00	25
SRH-2-3250	Blu/Blk	5.00	127	3250	1477	2.14	54	1.75	44	12.00	305	6.00	152	6.00	152	1.00	25



kineticsnoise.com
sales@kineticsnoise.com
1-800-959-1229

KINETICS™

4" Deflection Isolation Hangers Model SRH

Application

Kinetics SRH hangers are used to isolate suspended sources of both audible and inaudible noise and vibration. Suspended mechanical equipment such as in-line fans, cabinet fans, and piping and ductwork in close proximity to mechanical equipment are typical uses of Model SRH hangers.

Kinetics' minimum recommendation for the placement of spring hangers is that they be installed on all piping in the equipment room and on the first 50 ft (15 m) for piping that extends outside of the equipment room. For typical installations, the three spring hangers closest to the equipment should have equal deflection to the equipment isolators. The remaining spring hangers should have a minimum deflection of 1 in. (25 mm). In noise sensitive areas, the pipe hangers selected should have the same deflection as that specified for the equipment isolation and all piping in the building should be isolated.

Standard Model SRH hangers are shipped fully assembled and ready for installation in threaded metal rod suspension systems.

Model SRH hangers are available in a wide range of load and static deflection selections and can be provided with labor-saving accessories for adaption to wire or strap suspension systems, and spring may be preloaded for ease in erecting piping at a fixed elevation.



Description

Kinetics SRH Vibration Isolation hangers consist of free-standing, large diameter, laterally stable steel springs in series with an elastomer-inshear insert, assembled into a welded hanger bracket. Hangers incorporate a high deflection, color-coded spring element with load transfer plate and a 0.4 in. (10 mm) deflection elastomeric isolator complete with load transfer plate. To assure stability, the spring element has a minimum lateral spring stiffness of 1.0 times the rated vertical stiffness. Springs are polyester powder coated, with a 1000 hour salt spray rating per ASTM B-117. Hangers will allow a support rod misalignment through a 30° arc without short circuiting. Isolation brackets will carry a 500% overload without failure. Hangers are available in deflections from 4.09 in. to 4.40 in. (104 mm to 112 mm), and in capacities from 100 to 3850 lbs. (46 to 1747 kg). Model SRH hangers are superior to hangers which incorporate a spring only, which will transmit noise through the all-metal construction, and hangers which incorporate noise stop pads only, which will transmit low frequency vibration that a spring can isolate. Kinetics Model SRH combination hangers are recommended for the isolation of vibration produced by suspended mechanical equipment, low speed suspended fans, transformers, ductwork, piping, etc.

Hanger Type	Spring Color	Rated Load		Deflection		L		H		W		A		B		Dmax	
		lbs	kg	in	mm	in	mm	in	mm	in	mm	in	mm	in	mm	in	mm
SRH-4-100	Gray	100	45	4.09	104	3.18	81	16.00	406	9.38	238	4.00	102	6.00	152	0.88	22
SRH-4-250	Blue	250	114	4.22	107	3.18	81	16.00	406	9.38	238	4.00	102	6.00	152	0.88	22
SRH-4-500	Green	500	227	4.15	105	3.18	81	16.00	406	9.38	238	4.00	102	6.00	152	0.88	22
SRH-4-750	Black	750	341	4.22	107	3.18	81	16.00	406	9.38	238	4.00	102	6.00	152	0.88	22
SRH-4-1000	Red	1000	454	4.30	109	3.18	81	16.00	406	9.38	238	4.00	102	6.00	152	0.88	22
SRH-4-1250	Brown	1250	568	4.37	111	3.18	81	16.00	406	9.38	238	4.00	102	6.00	152	0.88	22
SRH-4-1600	Orange	1600	726	4.38	111	3.18	81	16.00	406	9.38	238	4.00	102	6.00	152	0.88	22
SRH-4-2250	Beige	2250	1023	4.53	115	3.52	89	18.50	470	13.50	343	6.00	152	8.00	203	1.00	25
SRH-4-2500	Bge/Blu	2500	1135	4.59	117	3.52	89	18.50	470	13.50	343	6.00	152	8.00	203	1.00	25
SRH-4-2750	Bge/Grn	2750	1249	4.65	118	3.52	89	18.50	470	13.50	343	6.00	152	8.00	203	1.00	25
SRH-4-3000	Bge/Blk	3000	1362	4.13	105	3.17	81	18.50	470	13.50	343	6.00	152	8.00	203	1.00	25
SRH-4-3250	Bge/Red	3250	1476	4.14	105	3.17	81	18.50	470	13.50	343	6.00	152	8.00	203	1.00	25
SRH-4-3500	Bge/Brn	3500	1589	4.14	105	3.17	81	18.50	470	13.50	343	6.00	152	8.00	203	1.00	25
SRH-4-3850	Bge/org	3850	1748	4.16	106	3.17	81	18.50	470	13.50	343	6.00	152	8.00	203	1.00	25

Specifications

Vibration isolators for suspended equipment with minimum static deflection requirement exceeding 0.4 in. (10 mm), and where both high and low frequency vibrations are to be isolated, shall be hangers consisting of a laterally stable steel spring in series with an elastomer-in-shear insert complete with load transfer plates and assembled in a welded steel bracket.

The bracket shall be finished with an polyester powder coating. The manufacturer shall provide independent laboratory testing showing that the bracket with this finish has endured a minimum of 1,000 hours of exposure to salt spray fog testing per ASTM B117 without signs of corrosion.

The elastomer insert shall be molded from oil-resistant compounds and shall be color coded to indicate load capacity and selected to operate within its published load range.

The spring element shall have a minimum lateral stiffness of 1.0 times the rated vertical stiffness.

Springs shall be color coded or otherwise identified to indicate load capacity.

The hanger bracket shall be designed to carry a 500% overload without failure and to allow a support rod misalignment through a 30° arc without metal-to-metal contact or other short circuit.

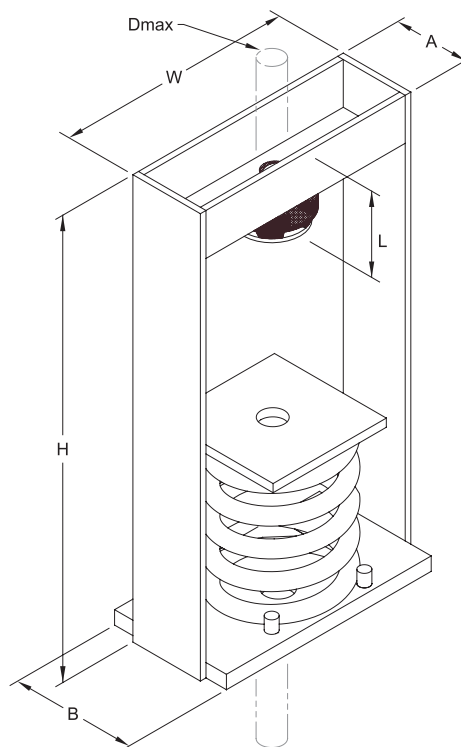

Isolation hangers shall be selected by the manufacturer for each specific application to comply with deflection requirements as shown on the Vibration Isolation Schedule or as indicated on the project documents.

The combination isolation hanger assembly with neoprene insert shall be Model SRH, as manufactured by Kinetics Noise Control, Inc.



kineticsnoise.com
sales@kineticsnoise.com
1-800-959-1229