



KINETICS® Alto

ACOUSTICAL WOOD COLLECTION

Alto acoustical wood features a grooved surface with two spacing options. Behind the grooves, visually-subtle openings allow sound energy to pass through the wood and be absorbed by hidden acoustical materials.

Select the desired finish and then choose 7-9/16" wide planks or panels up to 4' x 8' to customize the look of the project. The Kinetics' Acoustical Wood Collection enables designers to create beautiful auditoriums, atriums, conference rooms, courthouses and student centers finished in wood while providing acoustic function and comfort.

- Use on walls or ceilings
- Two standard groove spacings are available
- Groove pattern can be run to the edge creating a seamless look

SPECIFIABLE OPTIONS

- Field fabrication planks or panels
- Pre-fabricated ready-to-hang Ensemble
- Groove Spacing
- Veneer or laminate
- Edge finish
- Fire rated or non-fire rated core
- FSC® Certification Available Upon Request

Alto 8

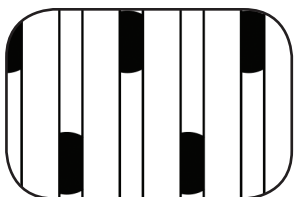

8mm groove spacing
(actual size)

Alto 16

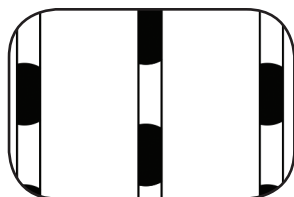

16mm groove spacing
(actual size)

Sound Absorption

Frequency	Bass					Mid Range								Treble				NRC	
	100	125	160	200	250	315	400	500	630	800	1000	1250	1600	2000	2500	3150	4000		5000
Alto 8 1" FG	0.18	0.19	0.22	0.28	0.41	0.61	0.76	1.00	1.09	1.11	0.95	0.72	0.54	0.44	0.42	0.42	0.49	0.71	0.70
Alto 8 2" FG	0.34	0.33	0.48	0.67	0.98	1.26	1.34	1.26	1.13	0.98	0.84	0.71	0.60	0.55	0.56	0.56	0.59	0.72	0.90
Alto 8 E-400 2" FG	0.96	0.84	0.79	0.91	1.01	1.02	1.02	1.11	1.12	1.04	0.93	0.85	0.70	0.62	0.59	0.59	0.66	0.78	0.90
Alto 16 1" FG	0.10	0.17	0.27	0.40	0.54	0.69	0.83	0.93	0.98	1.00	0.97	0.92	0.88	0.77	0.70	0.66	0.64	0.67	0.80
Alto 16 2" FG	0.33	0.43	0.71	0.82	0.99	1.00	1.02	0.95	0.94	0.91	0.86	0.81	0.81	0.78	0.74	0.70	0.73	0.74	0.90
Alto 16 E-400*	0.68	0.73	0.80	0.80	0.88	0.80	0.73	0.65	0.75	0.72	0.67	0.69	0.68	0.67	0.67	0.67	0.69	0.66	0.70

*Tested without fiberglass backer • FG = Fiberglass absorptive core • Noise Reduction Coefficient (NRC) frequencies shown in blue

Configurations

PLANKS

Alto tongue and groove planks create a hardwood floor-like appearance. Planks are easily field cut and nailed in place around doors, windows, and other architectural features.

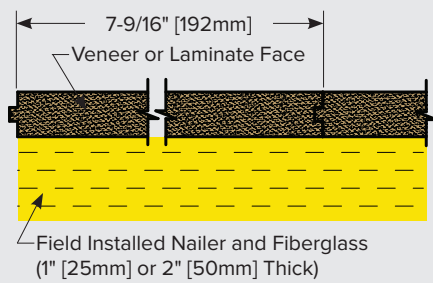

PANELS

Alto panels are hung on z-clips and can be custom sized to your dimensions.

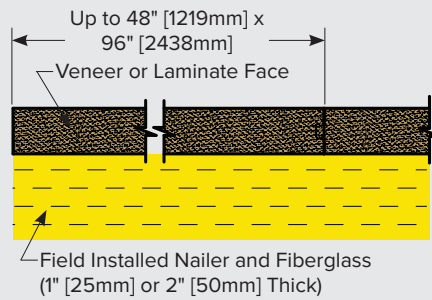

ENSEMBLE

Ensemble arrives as a ready to hang panel complete with fiberglass and frame.

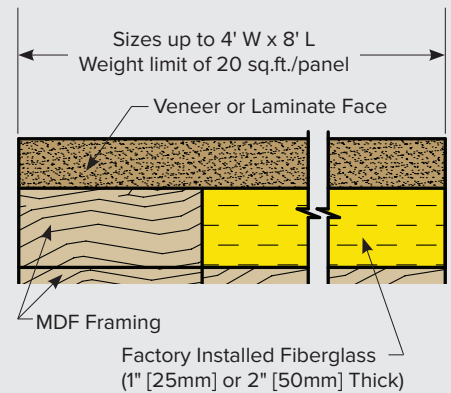

Options

Veneer	Core	Matching	Cuts	Finish	Edges
Maple*	MDF*	Random*	Plain Sliced (flat)*	Clearcoat (38 sheen)*	Bare MDF*
Cherry*	Fire Rated NAUF-MDF*	Book	Quarter	Laminate	Stain/Painted
Oak*	NAUF-MDF	Slip	Rift	Paint	Edge Banded
Walnut*	FR Particleboard	Sequence	Rotary	Unfinished**	Trim Pieces
Birch*	CARB.2				
Mahogany*					
Custom					

FSC® Certification Available Upon Request

Wood Notes: The beauty of wood is that it varies in color, grain pattern, and overall appearance and texture. Wood products are hygroscopic and therefore will shrink and expand with changes in humidity.

*Select for shortest lead time and/or cost savings

**To be finished in the field if matching other wood



kineticsnoise.com
sales@kineticsnoise.com
1-800-959-1229