

ESR Condenser Support Assembly

1. Position the condenser support so that it will be aligned with the support member on the equipment to be supported. See also the equipment or ESR submittal information for this location.
2. The condenser support is designed assuming that the roof to which it attaches is at the same elevation as is the structure that supports the ESR curb itself (for non-sloped applications). If the ESR is designed for a sloped roof, the Condenser support is designed to mount to a surface that would be consistent with the slope under the bulk of the ESR, but extended out to the condenser support location.

For example: If the ESR pedestals penetrate the roof decking and mount directly to the structural steel beneath, the condenser support should do the same.

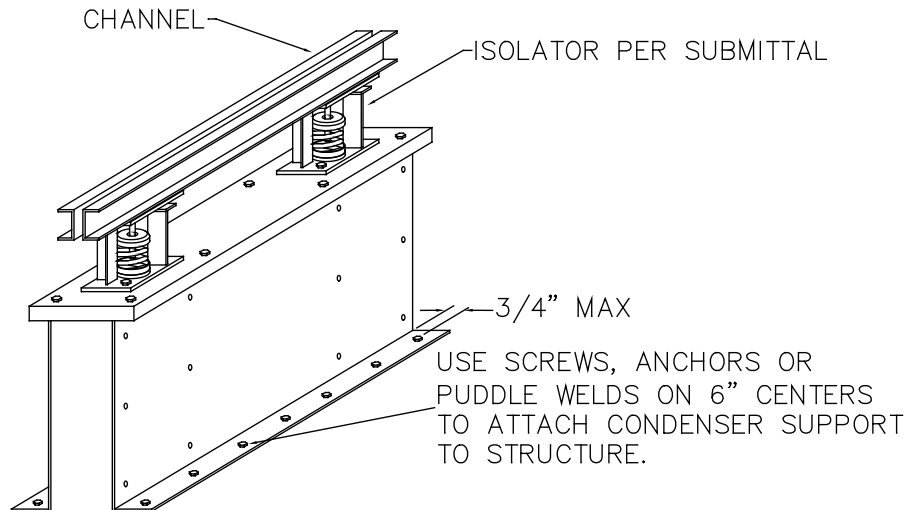

3. Attach to the roof structure using #10 screws on 6" (inch) centers, both sides. (As an option and depending on the material to which the condenser support is to be attached, 1/4" seismically rated anchors or puddle welds using 3/4" diameter washers can be substituted. In all cases, the connections must be within 3/4" of the vertical condenser support side panel.
4. After the equipment has been set, adjust the support isolators per the isolator instructions provided separately.
5. For seismic or high wind applications, the equipment must be welded or bolted to the support channel. For other applications it is not necessary to weld or bolt this joint.