

INSTALLATION INSTRUCTIONS FOR SHAA & SHAB HANGER

- 1) LOCATE EACH HANGER INTO POSITION BASED ON SUBMITTAL DRAWING USING COLOR CODED SPRINGS AS IDENTIFICATION.
- 2) ATTACH HANGER BOX TO UPPER HANGING ROD AS SHOWN IN SKETCH.
- 3) ATTACH EQUIPMENT TO LOWER HANGING ROD AS SHOWN IN SKETCH.
- 4) IF NECESSARY, ADJUST EQUIPMENT LEVEL BY THE LEVEL ADJUSTMENT NUT ON THE TOP OF THE COIL SPRING AS SHOWN IN THE SKETCH.
- 5) CHECK TO ENSURE ADEQUATE ALIGNMENT BETWEEN THE LARGE HOLE IN THE HANGER BOX (AT THE BASE OF THE SPRING) AND THE LOWER HANGING ROD.

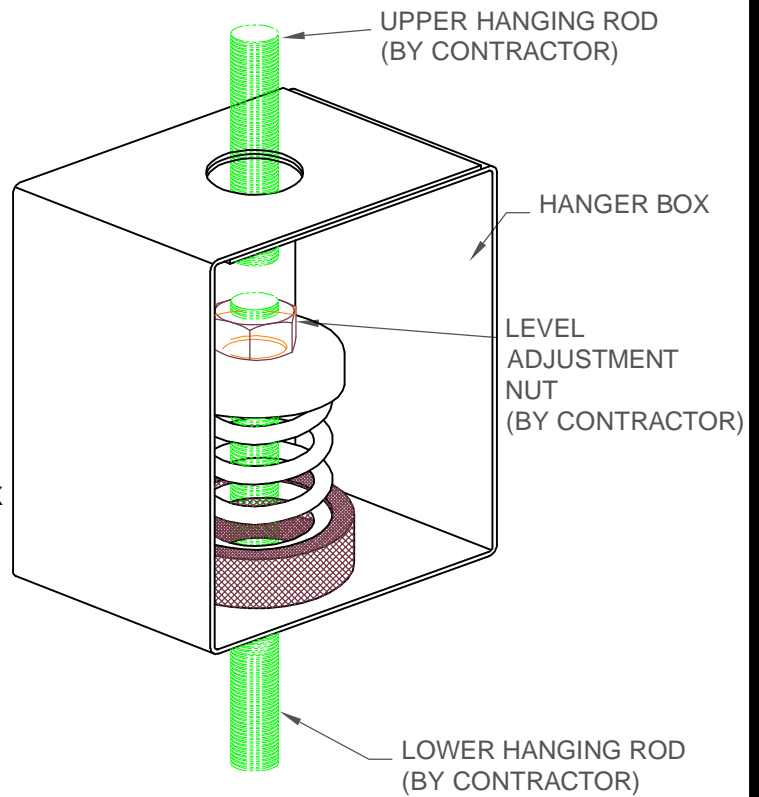

FOR SEISMIC APPLICATIONS

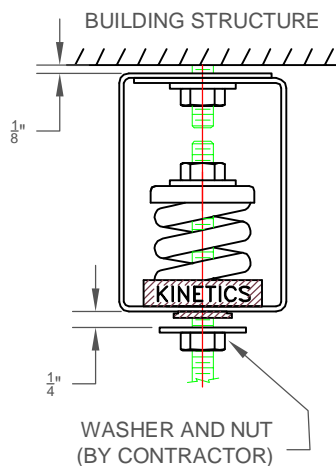

- A) HANGER BOX MUST BE ATTACHED WITH APPROX. $\frac{1}{8}$ " CLEARANCE BETWEEN HANGER BOX AND BUILDING STRUCTURE.
- B) INCLUDE AN ADDITIONAL WASHER AND NUT ON THE LOWER HANGER ROD BELOW THE HANGER BOX.
- C) THE WASHER O.D. MUST BE LARGER THAN THE ROD HOLE IN THE BOTTOM OF THE HANGER BOX.
- D) WHEN THE SYSTEM IS AT OPERATING WEIGHT, ADJUST THE LOWER NUT UNTIL THE WASHER IS $\frac{1}{4}$ " OFF THE BOTTOM OF THE HANGER BOX.