

# INSTALLATION INSTRUCTIONS

## MODEL CIB-F INERTIA BASE

- Place inertia base frame in its operating location on a sheet of poly with the rebar located toward the bottom of the base. If base has a pan/sheet metal bottom, block base frame to specified floor clearance with shims across width of base approx. 24" o.c..
- Locate the anchor bolts in the bolting templates provided with the base frame. (See bolt projection below.) If KNC is to provide the anchor bolts, they will be boxed with the isolators. (In some cases templates may not be provided.) The minimum distance between the anchor end and the bottom of the inertia base is 1 1/2".

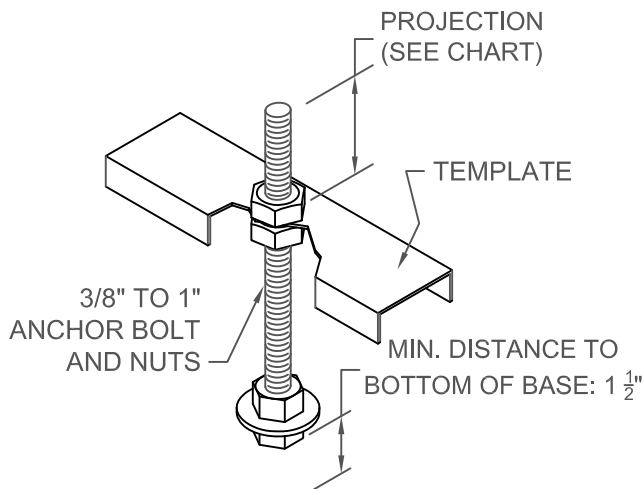
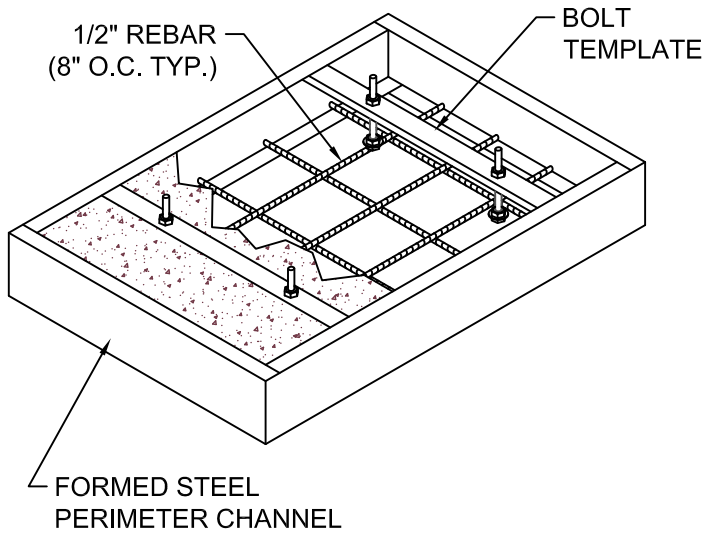

- After the anchor bolts have been located, check to insure they match equipment bolting pattern. Then fill the base with concrete and let it cure.
- When concrete has completely cured, lift up the base high enough to place the isolation pads under the base. For pan bottom bases, remove blocking.
- Equipment can now be installed on the base.

DIA	MAX PROJECTION
3/8	2.50
1/2	2.50
5/8	3.50
3/4	3.50
1	3.50

