



KINETICS NOISE CONTROL, INC
6300 IRELAN PLACE
DUBLIN, OHIO 43017
Ph 614-889-0480, FAX 614-889-0540

ESR Installation Instructions

General Information	Section 1
Packing List and Unpacking Instructions	Section 2
Basic Orientation and Assembly	Section 3
Alignment and Attachment to Structure	Section 4
Weather Seal Installation	Section 5
Flex Connector Support Assembly	Section 6
Condenser Support (Optional)	Section 7
Setting the Equipment	Section 8
Adjustment Procedure	Section 9
Final Installation and Test	Section 10

Note: In the event that installation of the type ESR base is not done in accordance with these instructions, the manufacturer will not accept responsibility for malfunctions of the base or any damage resulting from installation.

ESR Installation Instructions General Information

General Notes:

A standard Manufacturer's roof curb is NOT required for this installation.

The ESR Vibration isolation curb is designed to connect the equipment being isolated to the building structure and at the same time, provide a weather tight envelope. All pedestals must be supported on existing primary structural elements or on a purposely-sized secondary structural member. Full Seismic and wind ratings cannot be achieved unless the equipment is supported by and welded to adequately sized structural steel elements. Bolted attachment to other materials is possible however, but such a connection would include a significant reduction in the wind or seismic restraint capability.

Refer to the ESR submittal information for base drawings, isolator identification, duct flex connector supports and roof slope information.

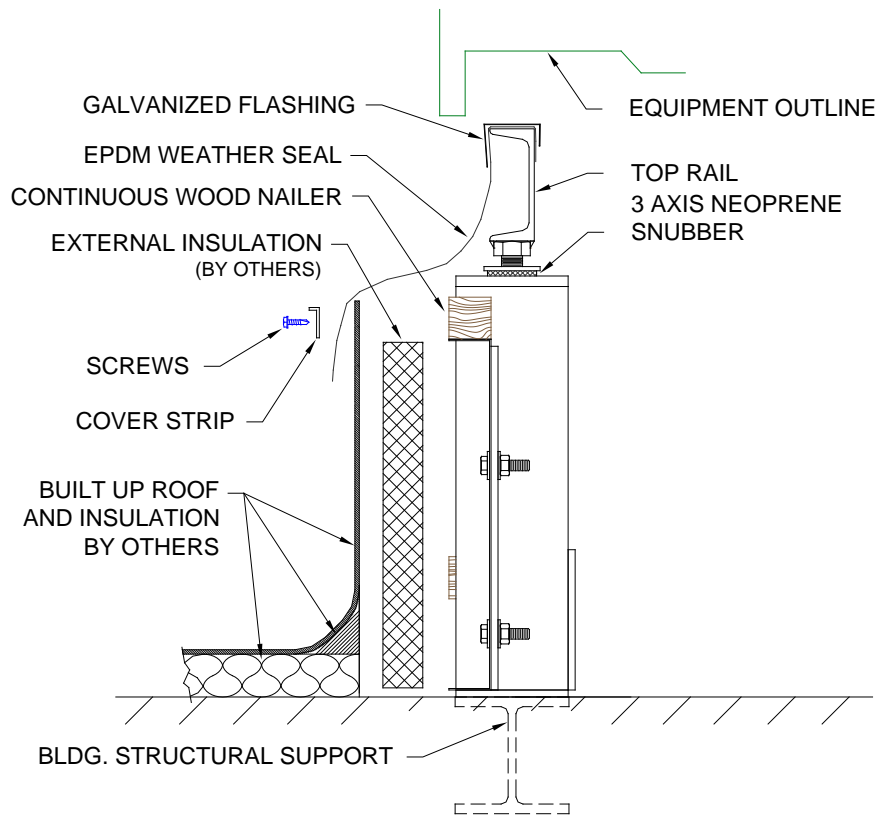

Typical Section Through ESR

INS-91-01.00
 Section 1
 1-1



KINETICS NOISE CONTROL, INC
6300 IRELAN PLACE
DUBLIN, OHIO 43017
Ph 614-889-0480, FAX 614-889-0540

ESR Standard Packing List and Unpacking Instructions

Carefully unpack the ESR and layout parts for identification. (See packing list below for included materials). Promptly report any shipping damage to the carrier.

Packing List for Standard ESR components

Two (2) side rail assemblies, including both top (floating) and bottom (fixed) curb members and the interfacing spring pedestals. (Tagged rails A and B.)

(For Rails that exceed 24 ft in length, these will be split into (2) sections each for shipping and will include hardware to connect the 2 sections together.)

Two (2) galvanized end channels (fixed portion of the curb). (Tagged rails C and D)

Two (2) 4" structural end channels (Isolated portion of the curb). (Tagged rails C and D)

Top and Bottom cross braces, if required. The quantity of these will vary based on the length of the ESR Specified. The exact number provided on a particular unit is listed on the submittal drawing for that unit.

EPDM weather seal material (equal in length to the total of all 4 sides plus a reasonable drop allowance.)

Galvanized flashing clip for clamping the EPDM weather seal to the top of the isolated channel member. (This is provided in 10 ft lengths with a total quantity provided to equal the length of all (4) sides plus a reasonable drop allowance.)

Cover strip for clamping the EPDM weather seal to the nailer on the fixed portion of the curb. (This is provided in 5 ft lengths with a total quantity provided to equal the length of all (4) sides plus a reasonable drop allowance.)

Spring pocket cover plates, one (1) for each pedestal.

Four (4) formed corner attachment brackets for bolting the fixed curb corners together.

Miscellaneous hardware consisting of fixed corner plate bolts, nuts, Isolated channel corner bolts, nuts, adhesive strips two (2) for sealing weather seal where the EPDM weather seal is joined, and caulk/screws for sealing and attaching pedestal pocket cover plates. If rails A and B are split, additional hardware is included for the split connection.

NO.	QTY	DESCRIPTION
1	2	SIDE RAIL ASSEMBLIES
2	2	END TOP CHANNEL (C4x5.4)
3	2	GALVANIZED END CHANNEL & NAILER
4	#	BOTTOM BRACE
5	#	TOP BRACE
6	4	GALVANIZED CORNER ANGLES (SLOTTED HOLES)
7	4	WOOD STUD END PIECE FOR PEDESTALS

QUANTITY VARIES
 * ALL NOT SHOWN

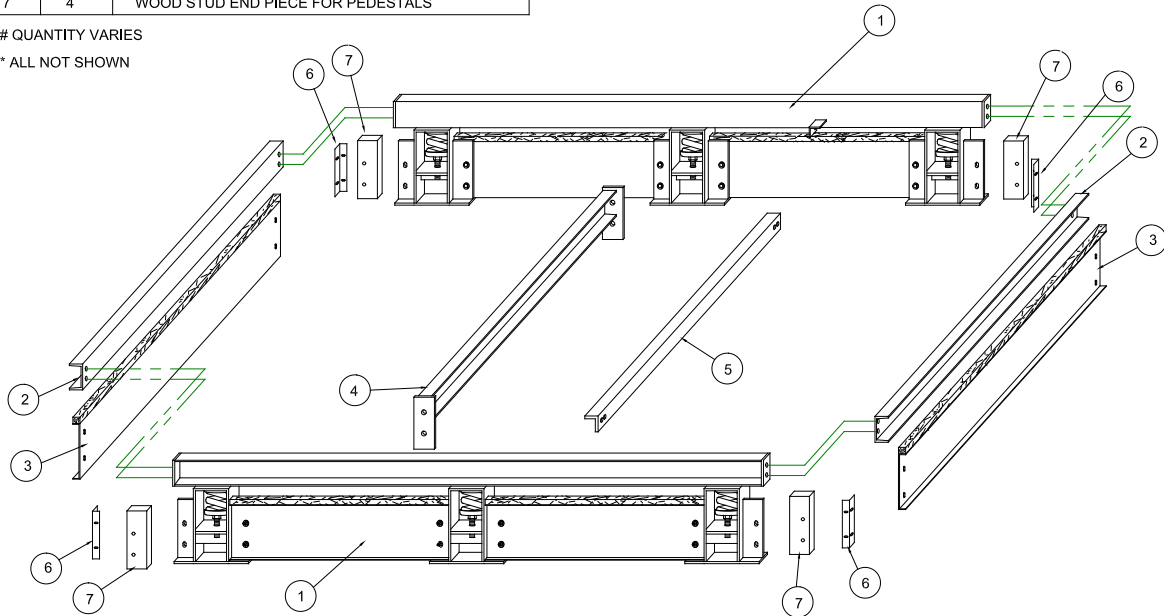

Additional components required for common options are listed below:

Condensor Island Support

If fitted with an island support, this section will be provided preassembled. It includes the fixed curb element, the isolated rail section and the interfacing isolators.

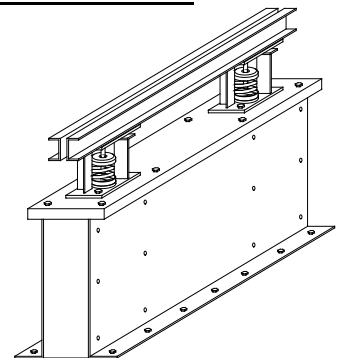

Duct Flex Connector Supports

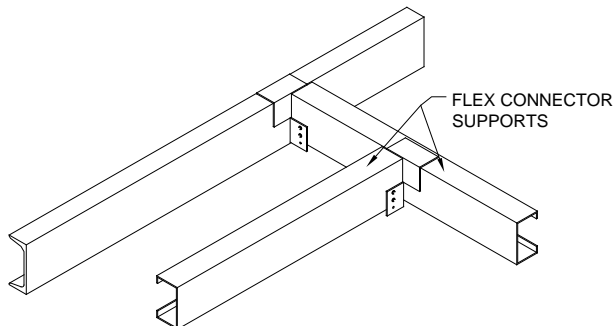

The flex connector supports consist roll formed structural members cut to lengths that allow them to be placed on the curb and offer a feature to which the (fixed) duct systems within the building envelope can be connected (via a flexible membrane). The number of support channels provided is dependent on the inlet and outlet arrangement on the underside of the AHU,

but most commonly involves eight (8) sections. Attachment clips to connect the members together are also provided with a quantity of (2) per channel.

INS-91-02.00

Section 2

2-2



KINETICS NOISE CONTROL, INC
6300 IRELAN PLACE
DUBLIN, OHIO 43017
Ph 614-889-0480, FAX 614-889-0540

ESR (Drip Pan) Packing List and Unpacking Instructions

Carefully unpack the ESR and layout parts for identification. (See packing list below for included materials). Promptly report any shipping damage to the carrier.

Packing List for ESR (with Drip Pan) components

Two (2) side rail assemblies, including both top (floating) and bottom (fixed) curb members and the interfacing spring pedestals. (Tagged rails A and B.)

(For Rails that exceed 24 ft in length, these will be split into (2) sections each for shipping and will include hardware to connect the 2 sections together.)

Two (2) galvanized end channels (fixed portion of the curb). (Tagged rail C and D)

One (1) 4" structural end channel (Isolated portion of the curb). (Tagged rail C)

One (1) 4" structural Intermediate channel (Isolated portion of the curb). (Tagged rail E)

One (1) 4" Open end channel. (Isolated portion of the curb) (Tagged rail D)

One (1) Drip pan (upper portion)

One (1) Drip pan (lower portion)

Top and Bottom cross braces, if required. The quantity of these will vary based on the length of the ESR Specified. The exact number provided on a particular unit is listed on the submittal drawing for that unit.

EPDM weather seal material (equal in length to the total of all 4 sides plus a reasonable drop allowance.)

Galvanized flashing clip for clamping the EPDM weather seal to the top of the isolated channel member. (This is provided in 10 ft lengths with a total quantity provided to equal the length of all (4) sides plus a reasonable drop allowance.)

Cover strip for clamping the EPDM weather seal to the nailer on the fixed portion of the curb. (This is provided in 5 ft lengths with a total quantity provided to equal the length of all (4) sides plus a reasonable drop allowance.)

Spring pocket cover plates, one (1) for each pedestal.

Four (4) formed corner attachment brackets for bolting the fixed curb corners together.

INS-91-02.A0
Section 2
2a-1

Miscellaneous hardware consisting of fixed corner plate bolts, nuts, Isolated channel corner bolts, nuts, adhesive strips two (2) for sealing weather seal where the EPDM weather seal is joined, and caulk/screws for sealing and attaching pedestal pocket cover plates. If rails A and B are split, additional hardware is included for the split connection.

NO.	QTY	DESCRIPTION
1	2	SIDE RAIL ASSEMBLIES
2	1	END TOP CHANNEL (C6x8.2)
3	2	GALVANIZED END CHANNEL & NAILER
4	#	BOTTOM BRACE
5	#	TOP BRACE
6	4	GALVANIZED CORNER ANGLES (SLOTTED HOLES)
7	4	WOOD STUD END PIECE FOR PEDESTALS
8	1	END TOP RAIL (w/ OPENING FOR DRAIN PAN)
9	1	UPPER DRAIN PAN SUPPORT (C4x5.4)
10	#	GALV. DRAIN PANS

QUANTITY VARIES
 * ALL NOT SHOWN

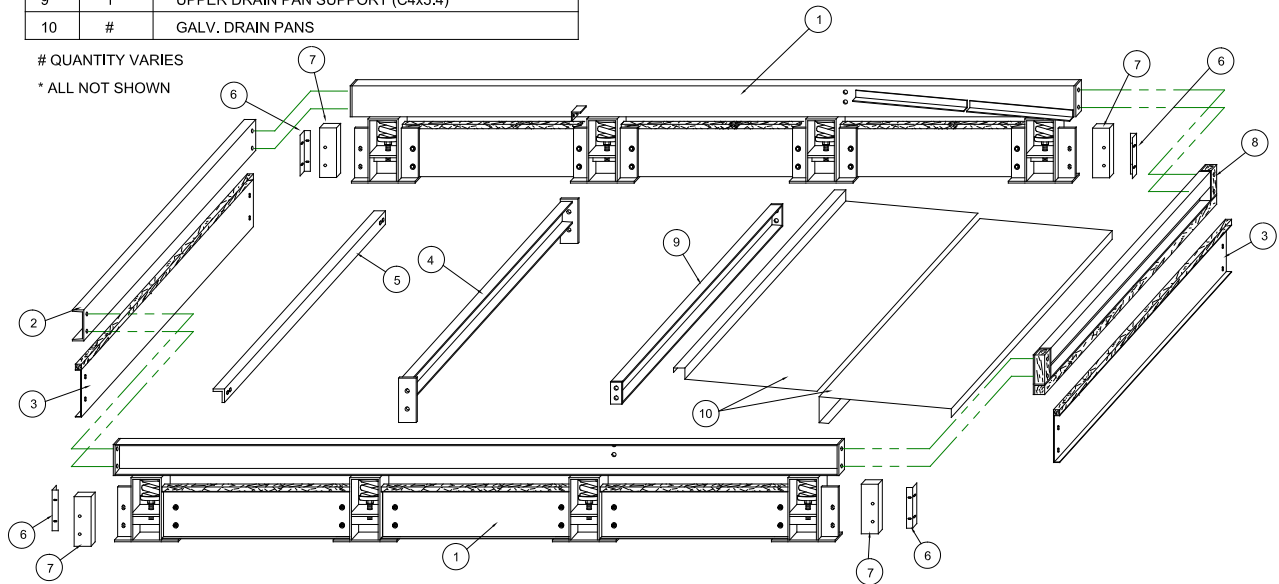

Additional components required for common options are listed below:

Duct Flex Connector Supports

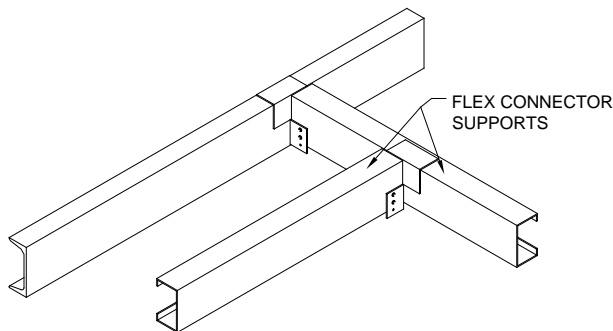

The flex connector supports consist roll formed structural members cut to lengths that allow them to be placed on the curb and offer a feature to which the (fixed) duct systems within the building envelope can be connected (via a flexible membrane). The number of support channels provided is dependent on the inlet and outlet arrangement on the underside of the AHU,

but most commonly involves eight (8) sections. Attachment clips to connect the members together are also provided with a quantity of (2) per channel.

Packing List for Sloped Roof and Extended Height Curb System ESR components

Galvanized side extension pieces. The total quantity provided is equal to the number of spring pedestals on the curb minus 2. These are sized to fit comfortably between each set of adjacent spring pedestal housings. If the corner spring pedestals do not fit tightly into the corner four (4) additional short side extension pieces will also be provided for use in the corners.

Two (2) Galvanized end extension pieces. One to match each rail C and rail D.

If the corner spring pedestals are not fit tightly into the corner, side pedestal covers in a quantity equal to the number of pedestals are included. If the corner spring pedestals are tightly fit into the corners, four (4) of the above side pedestal covers will be replaced with end pedestal covers.

#8 TEK screws for attachment of the extensions.

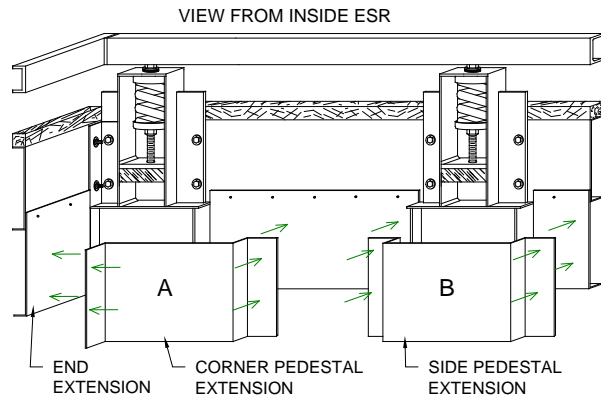
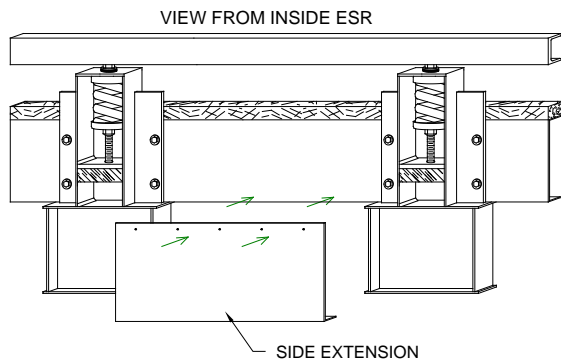

Note: For some sloped roof applications, not all side extension parts may be provided or required. For standard height curbs, the curb will be elevated such that the “standard height” point of the curb is aligned with the “high” point on the slope. If the slope runs parallel to one of the curb rails, that entire rail will be at standard height and no extension panels will be included.

Packing List for Pipe Chase Components

- Two (2) Pipe Chase Top Side Rails
- Two (2) Pipe Chase Bottom Side Rails
- One (1) Pipe Chase Top End Rail
- One (1) Pipe Chase Bottom End Rail
- Two (2) 6 Hole Corner Angles
- Two (2) 6 Hole Formed Corner Angles
- Two (2) 35 lb capacity Spring Isolator Coils
- Miscellaneous bolts and hardware

NO.	QTY	DESCRIPTION
1	2	PIPE CHASE CORNER ANGLES
2	3	PIPE CHASE TOP RAILS (2 SIDE, 1 FRONT)
3	3	PIPE CHASE BOTTOM CHANNEL (2 SIDES, 1 FRONT)
4	2	FORMED PIPE CHASE CORNER ANGLES

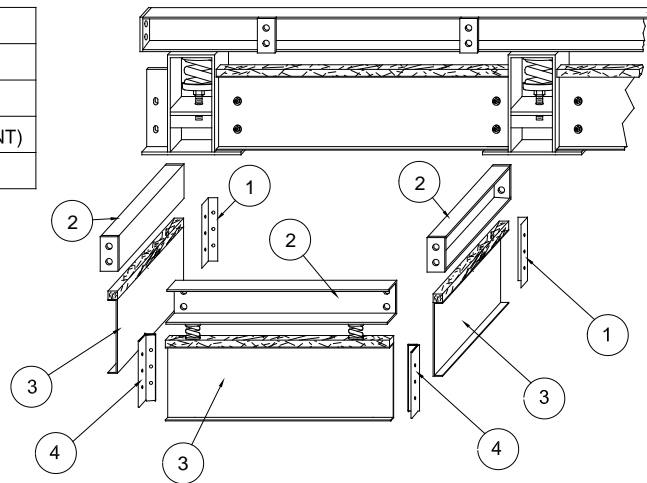

ESR Basic Orientation and Assembly

1. Determine the orientation of the ESR relative to the equipment by matching the identified end of the ESR submittal information with the corresponding end on the equipment. (May be marked "Cond End", "Supply End", etc.) Orient all tagged components in accordance with this equipment orientation and the sketch below.

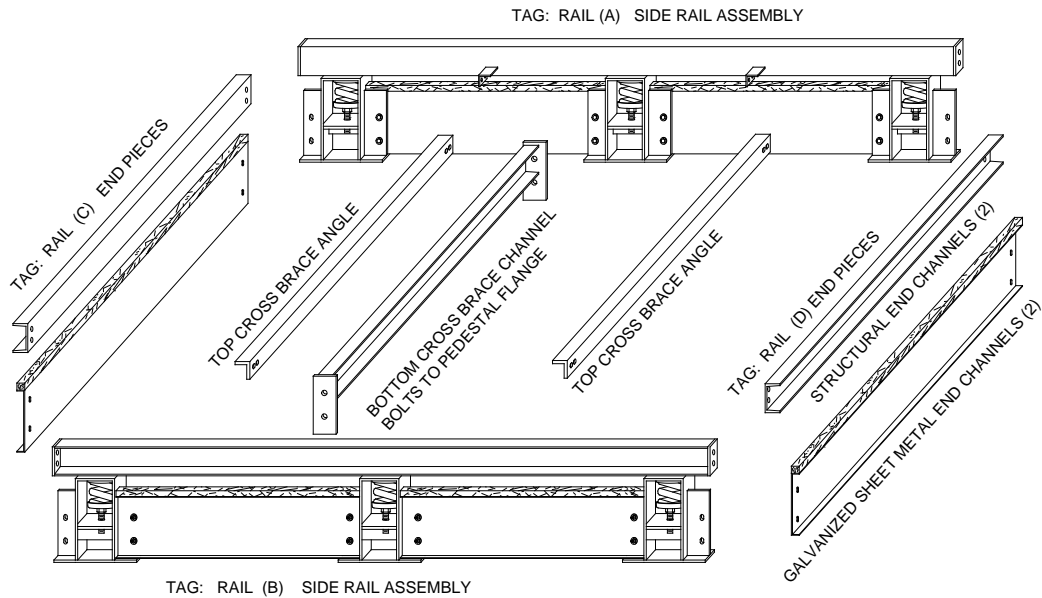

Note the Placement of Rails A, B, C and D. Improper placement can result in over or under loaded isolators and excessive vibration transmission.

2. Lay the ESR side rail assemblies complete with the pre-located spring pedestals on the building structure.
3. Using the 3/8" hex head screws, nuts and washers removed from the shipping carton, bolt together the upper channel sections as shown below to form the perimeter of the isolated portion of the curb.

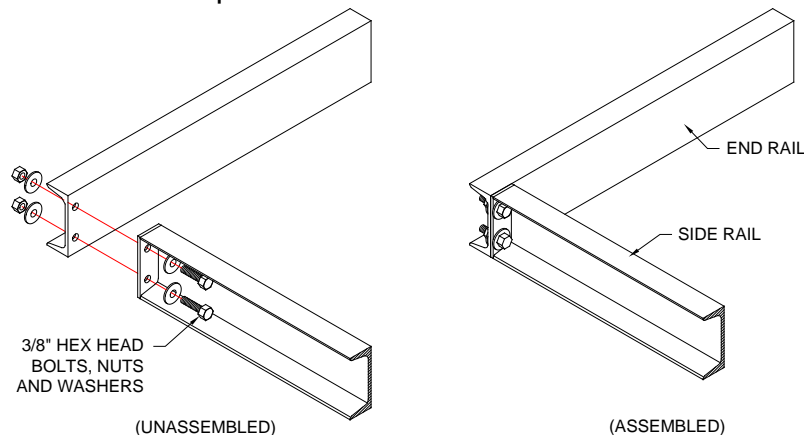

4. If a splice is required for the top channel, refer to the sketch below for the connection arrangement. First bolt and then weld around these connections.

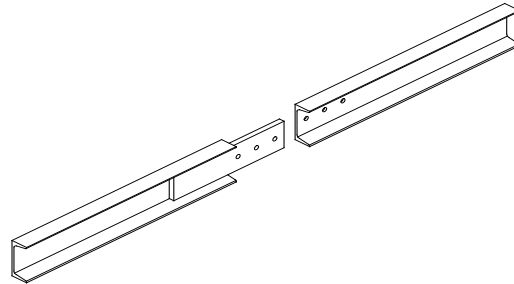

5. Fasten together all bottom galvanized channel sections to form the perimeter of the fixed portion of the curb. Depending on the curb dimensions, the corner arrangement will be per one of the sketches below. Assemble the end channels using the punched, formed corner angle brackets provided in the carton. Note that the holes are slotted to facilitate alignment and adjustment. All connections should be made using 3/8" nut, bolt and flat washers provided.

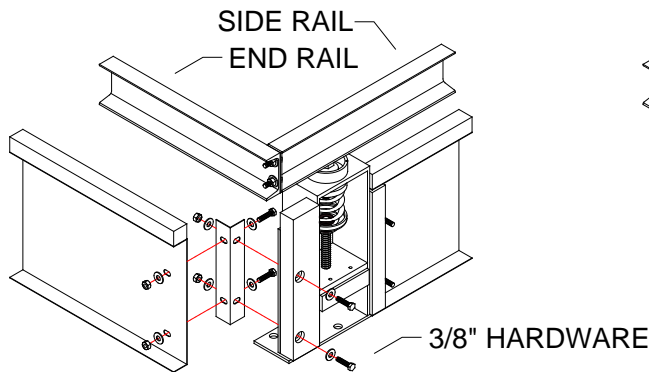

UNASSEMBLED

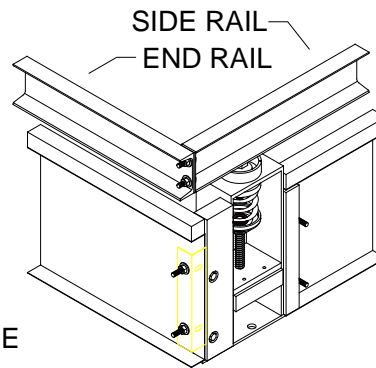

ASSEMBLED

BOTTOM CORNER ASSEMBLY (TYPICAL, WITH PEDESTAL AT END OF SIDE RAIL)

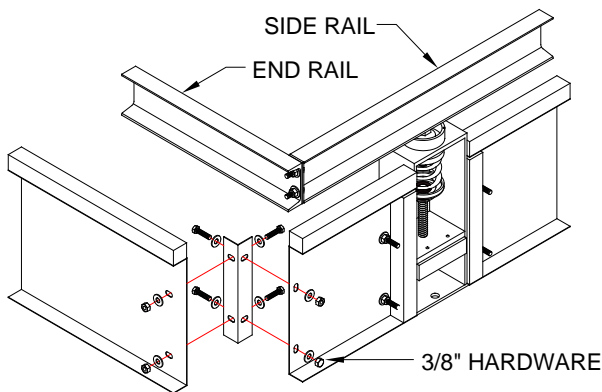

UNASSEMBLED

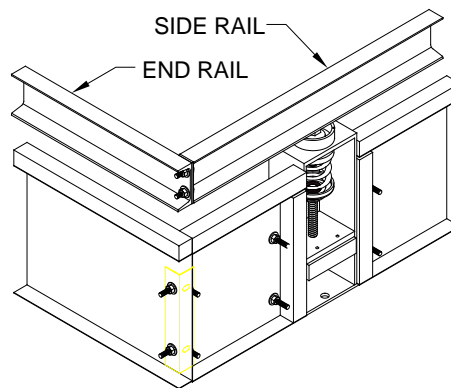

ASSEMBLED

BOTTOM CORNER ASSEMBLY (ALTERNATE, WITH PEDESTAL INBOARD FROM END OF RAIL)

6. If cross braces are indicated for this installation, space the lower cross brace channels as indicated in the supplied submittal drawing. Note that the braces will be attached using the same bolts that attach the formed galvanized side channel to the spring pedestals. The cross brace as supplied is slightly too the short for a direct connection (to allow for adjustment). Align the sides and use the provided 3/8" washers as shims on one end of the cross brace to fill the gap before tightening the attachment bolts.

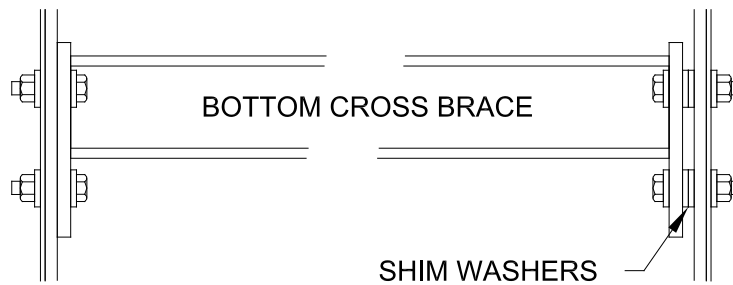

Installation of the upper cross brace (if indicated) is accomplished by bolting the cross frame angle to the bolt tabs welded to the top perimeter channels as shown below.

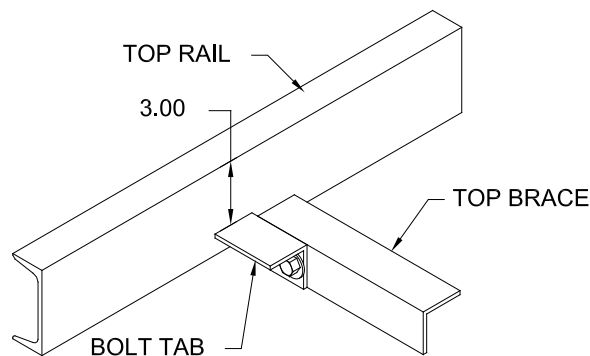

If this assembly includes a Pipe Chase, is taller than standard height (20.25" for 1 or 2" deflection systems or 21.25" for 4" deflection systems), or mounts to a sloped roof, some additional assembly steps are required at this point. Refer to later portions of this section for further detail.

Drip Pan ESR Basic Orientation and Assembly

1. Determine the orientation of the ESR relative to the equipment by matching the identified end of the ESR submittal information with the corresponding end on the equipment. (May be marked "Cond End", "Supply End", etc.) Orient all tagged components in accordance with this equipment orientation and the sketch below.

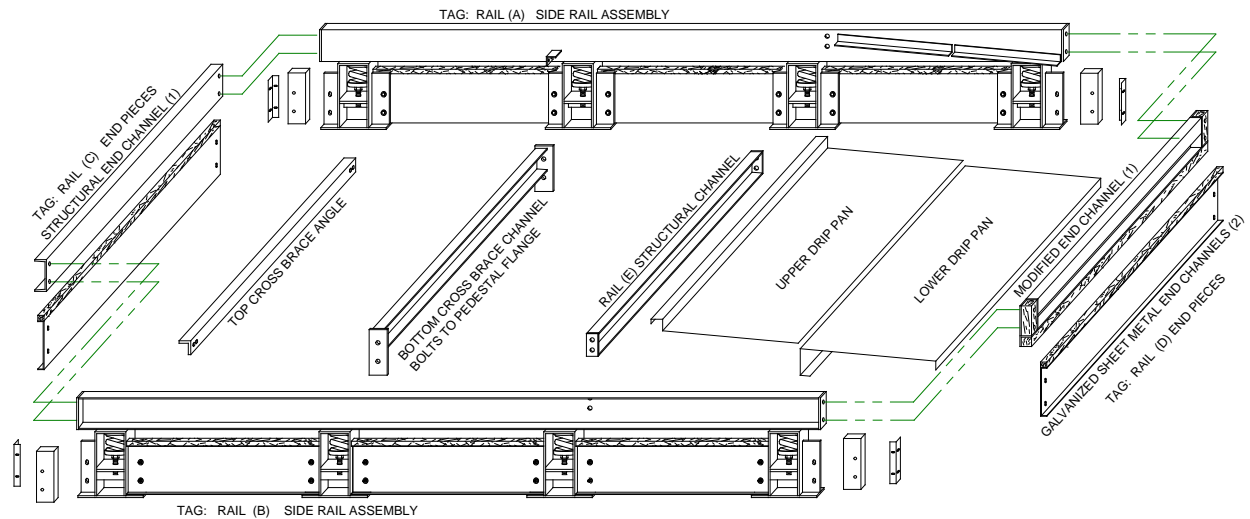

Note the Placement of Rails A, B, C, D and E. Improper placement can result in over or under loaded isolators and excessive vibration transmission. Rail D should be installed with the open area at the bottom.

2. Lay the ESR side rail assemblies complete with the pre-located spring pedestals on the building structure.
3. Using the 3/8" hex head screws, nuts and washers removed from the shipping carton, bolt together the upper channel sections as shown below to form the perimeter of the isolated portion of the curb.

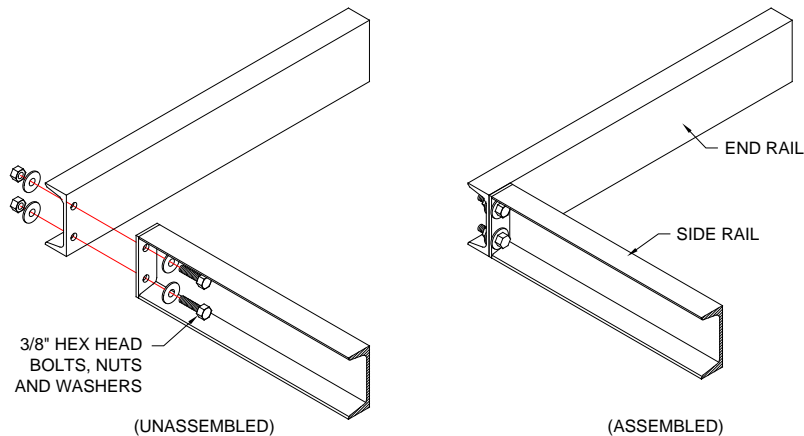

4. If a splice is required for the top channel, refer to the sketch below for the connection arrangement. First bolt and then weld around these connections.

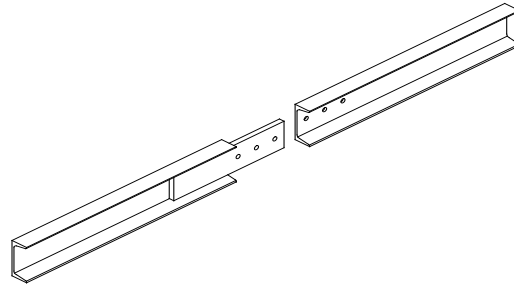

4. Fasten together all bottom galvanized channel sections to form the perimeter of the fixed portion of the curb. Depending on the curb dimensions, the corner arrangement will be per one of the sketches below. Assemble the end channels using the punched, formed corner angle brackets provided in the carton. Note that the holes are slotted to facilitate alignment and adjustment. All connections should be made using 3/8" nut, bolt and flat washers provided.

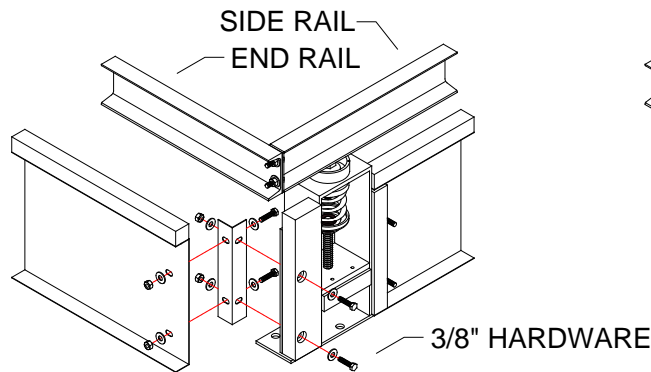

UNASSEMBLED

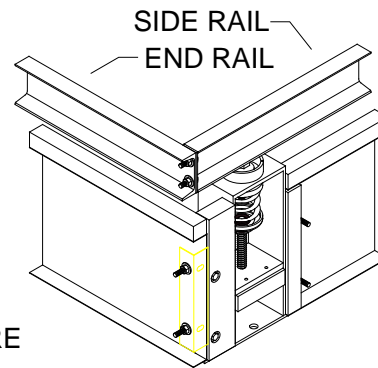

ASSEMBLED

BOTTOM CORNER ASSEMBLY (TYPICAL, WITH PEDESTAL AT END OF SIDE RAIL)

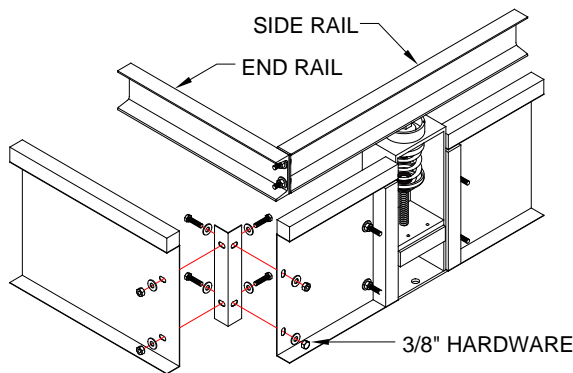

UNASSEMBLED

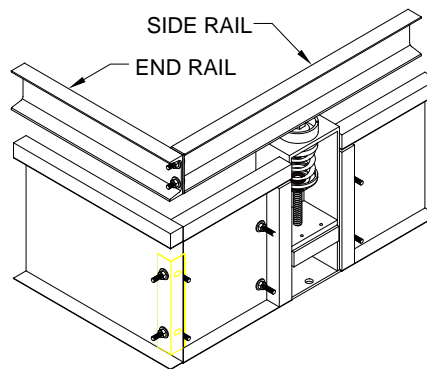

ASSEMBLED

BOTTOM CORNER ASSEMBLY (ALTERNATE, WITH PEDESTAL INBOARD FROM END OF RAIL)

5. Bolt Rail E into place at the interior end of the drip pan.

6. If cross braces are indicated for this installation, space the lower cross brace channels as indicated in the supplied submittal drawing. Note that the braces will be attached using the same bolts that attach the formed galvanized side channel to the spring pedestals. The cross brace as supplied is slightly too the short for a direct connection (to allow for adjustment). Align the sides and use the provided 3/8" washers as shims on one end of the cross brace to fill the gap before tightening the attachment bolts.

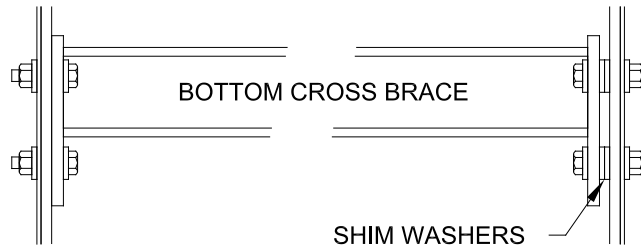

7. Installation of the upper cross brace (if indicated) is accomplished by bolting the cross frame angle to the bolt tabs welded to the top perimeter channels as shown below.

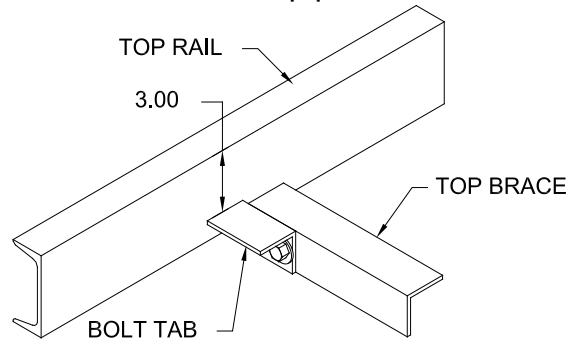

8. Place a strip of the provided 1/8" x 3/4" weather stripping material along the full length of the drip pan support angles attached to Rails A and B.

9. Place the lower drip pan section on the angles and weather stripping as shown. Do not screw down at this point.

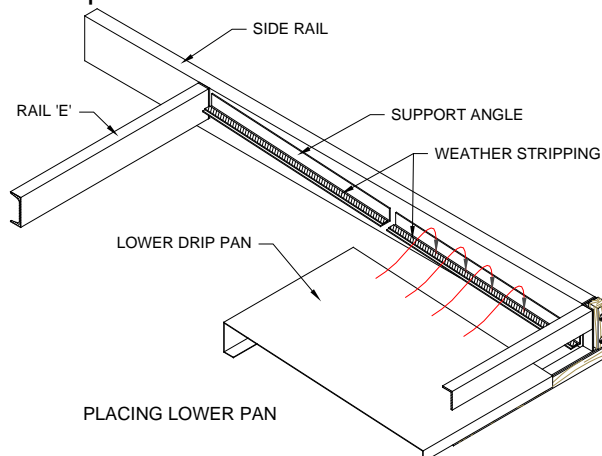

INS-91-03.01
 Section 3
 3-3

10. Place the upper drip pan section so that it overlaps the lower drip pan and so that the upper lip is supported on Rail E. In some instances, drip pans may be long enough that they are made up of more than 2 sections, if so overlap the central sections, fitting the upper drip pan section in last.

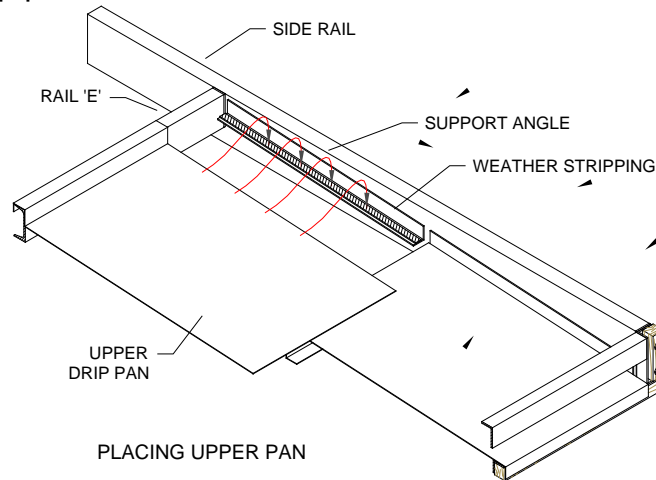

11. Starting at the top, attach the drip pan sections to the support angles on the side rails using the provided 5' long aluminum cover strips and #8 TEK screws.

*Leave the bottom 2 ft of the drip pan and the lip attachment at Rail D alone at this point as the weather seal must be fitted into place before making these final connections. Refer to **Section 5** for the installation of the weather seal.*

With the weather seal in place, complete the following 2 steps.

12. Once the weather seal is inserted, the final screws connecting the drip pan to the support angles can be fitted as can the screws which connect the lower lip of the drip pan to the nailer at the bottom of Rail D.

13. Caulk all seams and joints to ensure that the assembly is water tight.

If this assembly includes a Pipe Chase, is taller than standard height (20.25" for 1 or 2" deflection systems or 21.25" for 4" deflection systems), or mounts to a sloped roof, some additional assembly steps are required at this point. Refer to later portions of this section for further detail.

ESR Slope/Extended Height Component Assembly

1. Attach the Galvanized Side Extensions with #8 TEK screws to fill the gap between the top of the roof structure and the bottom of the side panels on the ESR curb. Attach the End Extensions to the lower portion of the End Rails in a similar fashion. For Sloped Roofs, orient the extensions to follow the slope of the roof, leaving minimal gaps.
2. Where the corner pedestals are not tightly fit into the corners, four (4) short side extensions will be provided. These screw to the most outboard panels of each side rail.
3. Attach the Galvanized Side and Corner Pedestal Extensions with #8 TEK screws. If the pedestals are not in the corners, all pedestal extensions will be of the "Side" type. If the pedestals are in the corners, the four (4) corners will use "Corner" pedestal extensions. Both types are shown in the figure for clarity.

Note: Some Sloped ESR's will not require extensions on all 4 sides.

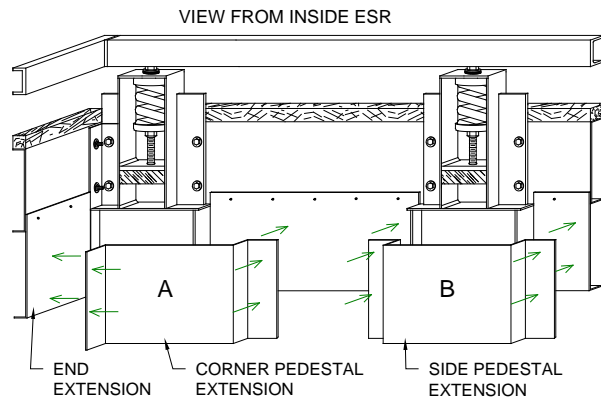
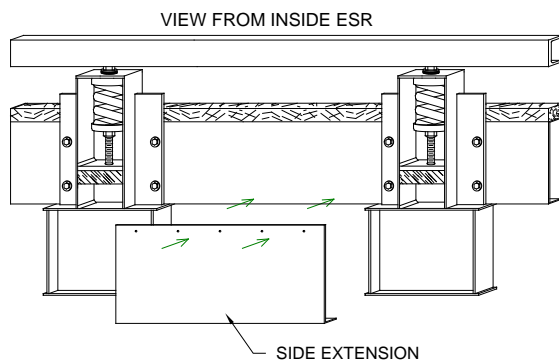

ESR Pipe Chase Assembly

1. Attach the top side pipe chase rails to the main ESR rail at the attachment tabs that are welded to the top side rails.
2. Attach the end rail to the side rails using the bolts provided.
3. Attach the bottom side pipe chase rails to the main ESR side rails directly under the top side rails using the sheet metal angle clips. Bolt as shown in the attached sketch using the provided hardware.
4. Using the formed angle clips provided slip the bottom end plate onto the side plates and secure it using the self tapping TEK Screws.
5. Snap the pipe chase support springs into the cups that are mounted to the end rail. These should bear against the underside of the top rail and may need to be forced into place.
6. Later when installing the weather stripping, it should be routed out and around the pipe chase to form a weather tight seal.

NO.	QTY	DESCRIPTION
1	2	PIPE CHASE CORNER ANGLES
2	3	PIPE CHASE TOP RAILS (2 SIDE, 1 FRONT)
3	3	PIPE CHASE BOTTOM CHANNEL (2 SIDES, 1 FRONT)
4	2	FORMED PIPE CHASE CORNER ANGLES

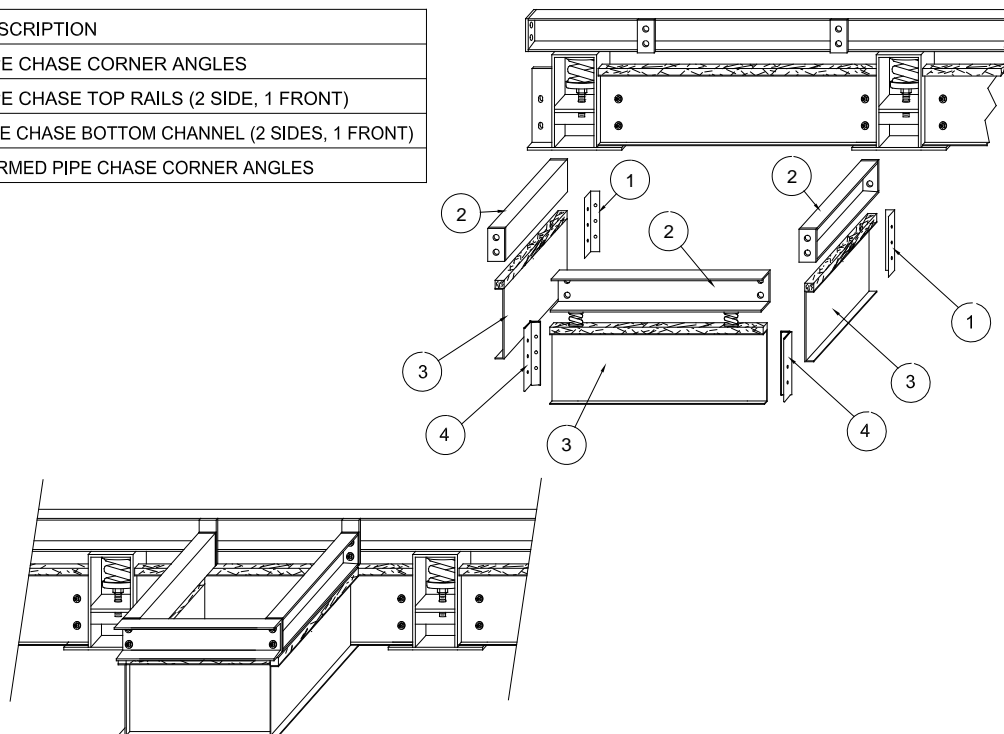

ASSEMBLED VIEW

INS-91-03.B0
 Section 3
 3b-1

ESR Alignment and Attachment to Structure

1. After assembling the curb and placing it in its final location, it is VITAL that the pedestals be aligned vertically so that the top surface of the pedestals are in the same plane $\pm 1/16"$. If necessary, shims should be fitted between the pedestal bases and the structural steel support members to ensure that this is the case.

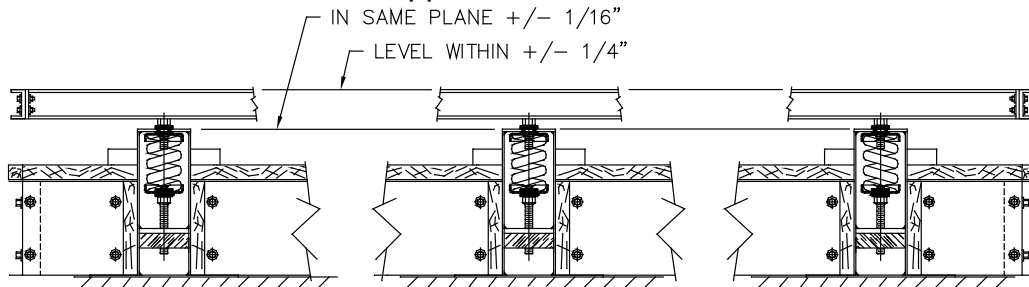

2. When working with sloped roof conditions, shims will likely be required at each spring pedestal location to ensure that the housings remain vertically oriented. While overall pedestal heights as provided by Kinetics are varied to account for changes in height between pedestals, slopes on the underside of the pedestals themselves are not addressed. In these cases, both the vertical orientation of the individual pedestals and the vertical alignment of the entire array must be addressed.

NOTE: Plastic spacers are fitted between the top of the pedestal housing and the underside of the equipment support rail. These are required for isolator adjustment and should not be removed at this point.

3. It is important that the sides of the curb be square and that the pedestals be in line. Diagonal measurements must be equal within $1/4"$ and pedestals along the long axis must be aligned within $1/8"$. Once this is accomplished, the pedestal bases should be welded or bolted to the supporting structural steel structure using a $1/4"$ weld the full length of the base plates.

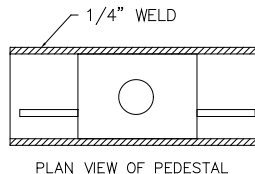

NOTE: (3) 5/8" diameter bolt holes are provided in each pedestal housing. These can be used for attachment to the building structure, either with through bolts or with concrete anchors. The use of bolts or anchors however, greatly decreases the seismic capacity and should not be attempted without confirmation from Kinetics that the capacity of this connection is adequate for the application.

The sheet metal panels between pedestals can be connected to the structure using #8 TEK Screws, puddle welds or any concrete anchorage device (depending on the material to which they are being attached) located on 18" centers (Max)

ESR Weather Seal Assembly

1. Install the EPDM material around the perimeter of the isolation rail by draping it across the top of the upper rail, leaving enough material for later connection to the wood nailer on the lower portion of the curb. Avoid cutting the material and arrange it to allow any joints to fall away from the corners. Pull the material to provide a good fit around the base. Trim the material on the inside of the corners as indicated to allow a smooth fit of the retaining channel clip over the 4" structural channel to retain the EPDM seal.

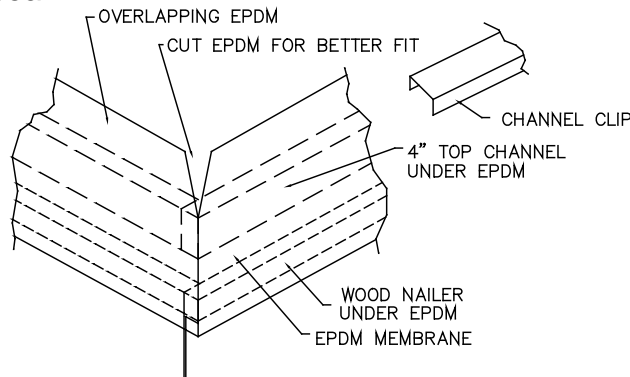

2. At the butt joint(s), cut the EPDM material so there is approximately a 4" overlap. Fold back the upper layer and clean the two surfaces that will be bonded together with a fully evaporating solvent such as alcohol.

Failure to clean these surfaces or the use of a non-evaporating solvent like kerosene will result in an improper seal at this joint.

3. Cut a piece of from the supplied adhesive (Manus-Bond 64-A) to match the overlap dimensions of the EPDM material. Sandwich it between the two layers in the overlapping area and firmly press the layers together.

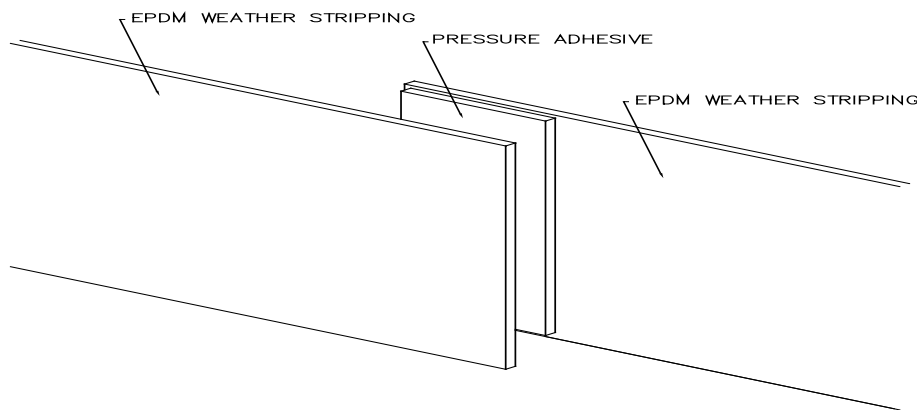

4. Do not secure the lower edge of the weather seal at this time. This should not be done until the supported equipment is in place and the system has been adjusted.

INS-91-05.00

Section 5

5-1

Drip Pan ESR Weather Seal Assembly

1. Install the EPDM material around the perimeter of the isolation rail by draping it across the top of the upper rail, leaving enough material for later connection to the wood nailer on the lower portion of the curb. Avoid cutting the material and arrange it to allow any joints to fall away from the corners. Pull the material to provide a good fit around the base. Trim the material on the inside of the corners as indicated to allow a smooth fit of the retaining channel clip over the 4" structural channel to retain the EPDM seal.

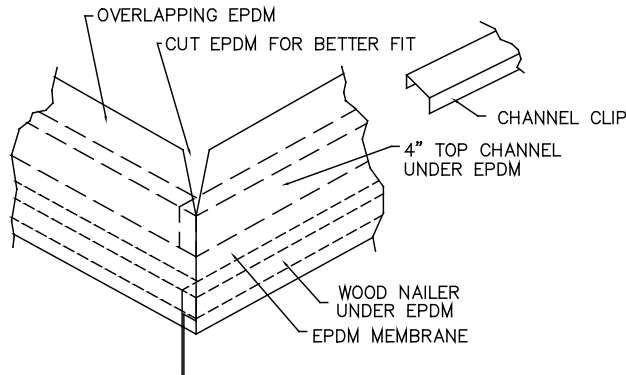

2. At the butt joint(s), cut the EPDM material so there is approximately a 4" overlap. Fold back the upper layer and clean the two surfaces that will be bonded together with a fully evaporating solvent such as alcohol.

Failure to clean these surfaces or the use of a non-evaporating solvent like kerosene will result in an improper seal at this joint.

3. Cut a piece of from the supplied adhesive (Manus-Bond 64-A) to match the overlap dimensions of the EPDM material. Sandwich it between the two layers in the overlapping area and firmly press the layers together.

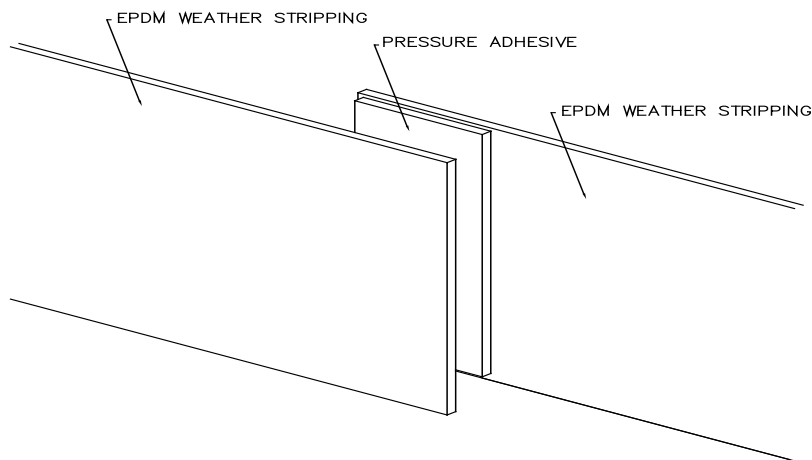

- At the end of the drip pan, the EPDM weather seal is to be inserted under the drip pan lip as shown below. (This must be done prior to screwing the drip pan lip to the Rail (See also Section 2)

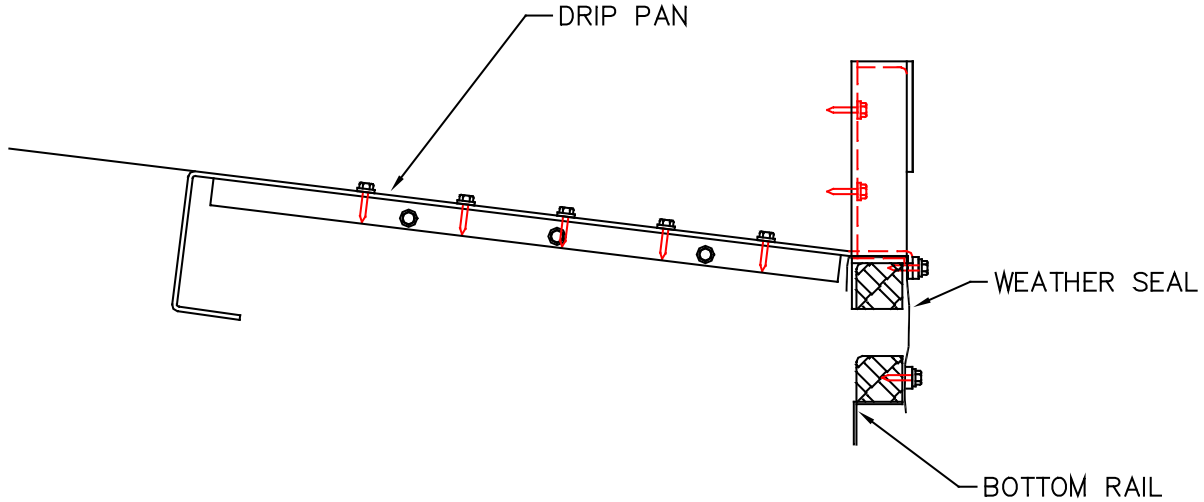

- To accomplish the above, the EPDM seal must first be notched at the drip pan corners as shown below.

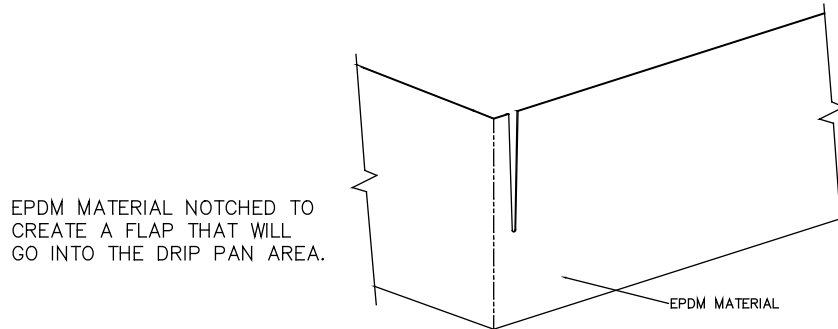

- The lower drip pan lip can be lifted at this point and the EPDM can then be folded into the opening and screwed to Rail D using the provided #8 TEK screws and caulked as shown below.

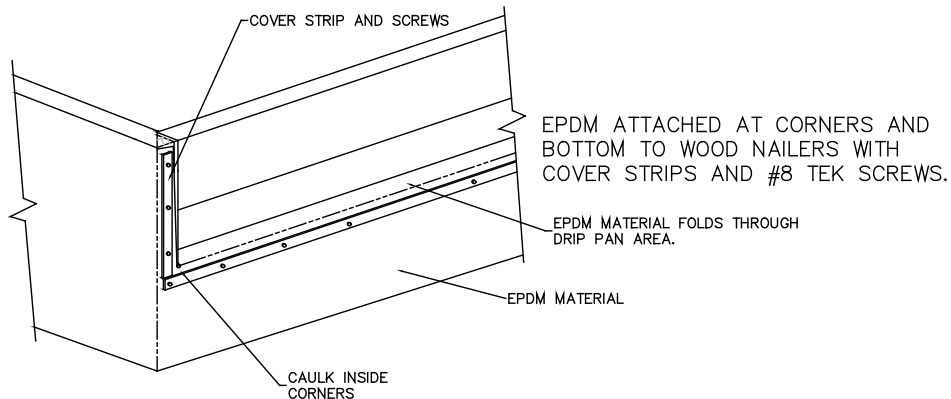

7. Once the EPDM is properly secured, the drip pan can be lowered over it and be secured to the rails as indicated in Section 2.

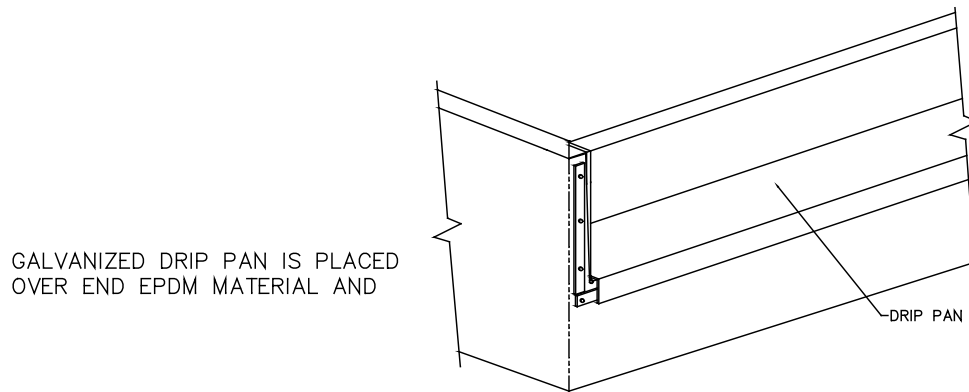

8. Do not secure the lower edge of the weather seal at this time. This should not be done until the supported equipment is in place and the system has been adjusted.

ESR Duct Flex Connector Support Assembly

1. Install the flex connector support channels in accordance with the submittal information. These are comprised of roll formed channel sections which have been cut to length and should be arranged in the curb to match the duct outlets on the underside of the mating AHU.

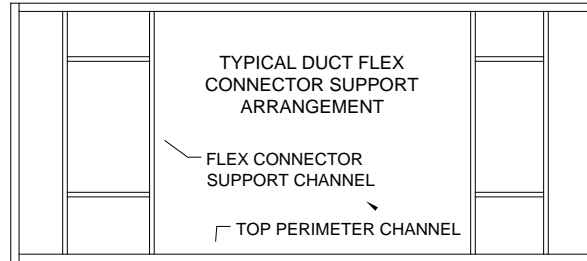

2. Measure any supply or return duct lips protruding on equipment. Adjust the height of the flex connector support channels to match these to form a positive seal between equipment and flex support channels.

(*) Note: Maximum standard adjustment on "duct block-off" is 2" below flush.

3. The support channels should be screwed to the flex connector support brackets using the provided #8 TEK screws and then hung either on the perimeter channel or attached to mating flex support channels as indicated below.

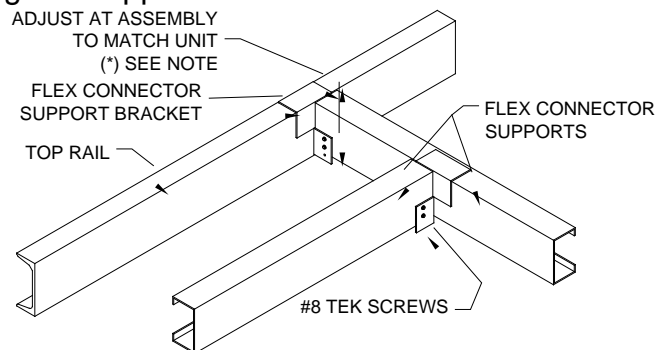

4. Install flex (by others) between the flex connector supports and the internal ducting in the building.

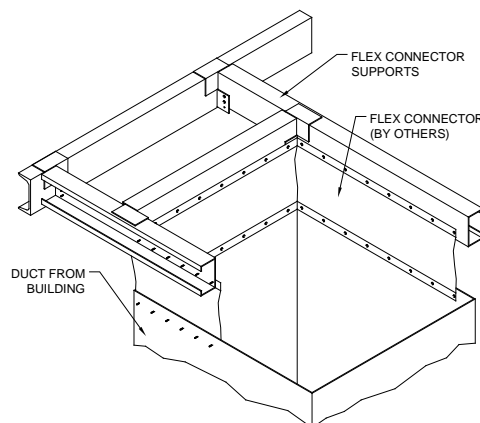

INS-91-06.00

Section 6

6-1

ESR Condenser Support Assembly

1. Position the condenser support so that it will be aligned with the support member on the equipment to be supported. See also the equipment or ESR submittal information for this location.
2. The condenser support is designed assuming that the roof to which it attaches is at the same elevation as is the structure that supports the ESR curb itself (for non-sloped applications). If the ESR is designed for a sloped roof, the Condenser support is designed to mount to a surface that would be consistent with the slope under the bulk of the ESR, but extended out to the condenser support location.

For example: If the ESR pedestals penetrate the roof decking and mount directly to the structural steel beneath, the condenser support should do the same.

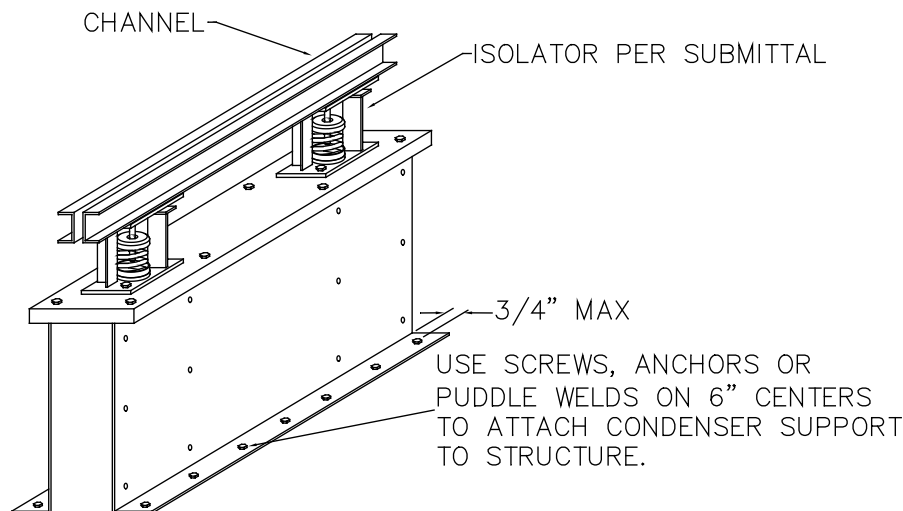

3. Attach to the roof structure using #10 screws on 6" (inch) centers, both sides. (As an option and depending on the material to which the condenser support is to be attached, 1/4" seismically rated anchors or puddle welds using 3/4" diameter washers can be substituted. In all cases, the connections must be within 3/4" of the vertical condenser support side panel.
4. After the equipment has been set, adjust the support isolators per the isolator instructions provided separately.
5. For seismic or high wind applications, the equipment must be welded or bolted to the support channel. For other applications it is not necessary to weld or bolt this joint.



KINETICS NOISE CONTROL, INC
6300 IRELAN PLACE
DUBLIN, OHIO 43017
Ph 614-889-0480, FAX 614-889-0540

ESR Setting Equipment

1. If using the gasketing material provided by the equipment vendor, check it to be sure that it is flat and smooth and will seal against the top of the isolation rail. If there is any concern about the ability of this material to seal, it should be removed and a bead of caulk applied to the top surface of the perimeter channels and flex connector support channels prior to setting the unit.
2. Check also the seal at the flex connector support locations. Ensure that the flex connector supports are aligned with the mating surfaces on the underside of the unit and that they are either provided with a flat smooth foam seal or are provided with a bead of caulk that will act as a seal.

Note: Foam seals are frequently preferred over caulk as when aligning the unit the caulk will tend to "glue" the ESR to the underside of the AHU making adjustment difficult.

3. DO NOT remove the plastic spacers that are fitted between the underside of the isolation support rail and the top of the spring pedestals. These are intended to support the equipment until the springs are adjusted.
4. Carefully align the supported equipment with the ESR and set it into place using caution not to damage the EPDM weather seal.
5. In high wind or seismic applications, the equipment must be bolted into place on the ESR. Generally (1) ½" diameter bolt per pedestal is adequate, but this should be verified using an appropriate analysis. Normal installation is to open access panels in the equipment and either use existing mounting holes or drill through the bottom of the unit in line with the rail. Holes should also be drilled in the top leg of the isolated channel and through bolts fitted.

ESR Adjustment Procedure

NOTE: Before adjusting the isolators on the ESR, it is necessary that the supported equipment be brought up to its installed operating weight. If the unit is to be filled with a fluid, this should be done prior to final adjustment of the isolators.

Tip: Prior to adjusting the leveling nuts and screws, apply a grease with EP additives to the leveling screw to reduce friction.

Depending on the height of the spring coil and the required spring deflection in service, the isolators may be fitted with either a single adjustment or a double adjustment leveling screw. The single adjustment screws are used on all 1" deflection and most 2" deflection ESRs. The double adjustment screws are used in rare instances on 2" deflection but on all 4" deflection ESRs. (Note: Where 3" deflection Isolators are specified, 4" are provided.)

Procedures for both are provided below

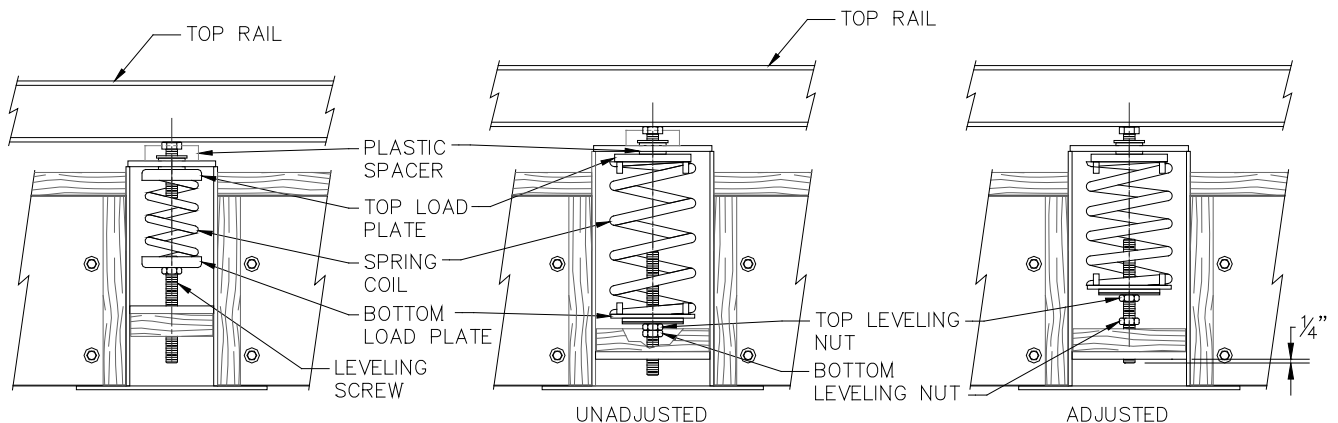

Single Adjustment Leveling Screw

Double Adjustment Leveling Screw

NOTE: The load plate on top of the spring coil is not part of the adjustment procedure and should be left at the location set at the factory.

1. Single Adjustment Leveling Screw Procedure: Reach through the access opening of the pedestals and rotate the leveling screw counter-clockwise several complete turns at each pedestal. Do this at each pedestal until the plastic spacer is just barely free to move. It may be necessary to make several circuits of the isolators as adjustments on adjacent pedestals may affect the load on those previously adjusted.

Double Adjustment Leveling Screw: Reach through the access opening of the pedestals and first rotate the bottom nut so that it moves upwards (counter clockwise). Turn it until the bottom end of the leveling screw still protrudes approximately ¼” through the bottom plate into which it is threaded.

Caution: Do not turn it further than this as continued adjustment can result in the leveling screw coming loose and the spring popping out which in turn could result in personal injury.

Continue the adjustment by holding the bottom nut fixed with a wrench and rotating the upper nut counter clockwise several complete turns at each pedestal. Do this at each pedestal until the plastic spacer is just barely free to move. It may be necessary to make several circuits of the isolators as adjustments on adjacent pedestals may affect the load on those previously adjusted.

Caution: Do not allow the leveling screw to turn further than as additional rotation can result in the leveling screw coming loose and the spring popping out which in turn could result in personal injury.

Do not over adjust the springs. Once all springs are adjusted, the plastic spacers can be broken with a chisel and removed. Confirm that the unit is now level within the manufacturer’s specifications.

Note: If it is found during adjustment that some of the restraint snubbers are tight on the bottom when others are tight on the top and that adjustment does not cure this situation, it is likely that the pedestals are not level. Refer back to section 4 for more information.

2. Caulk around the spring access plates and attach to the wood nailer using #8 TEK screws.

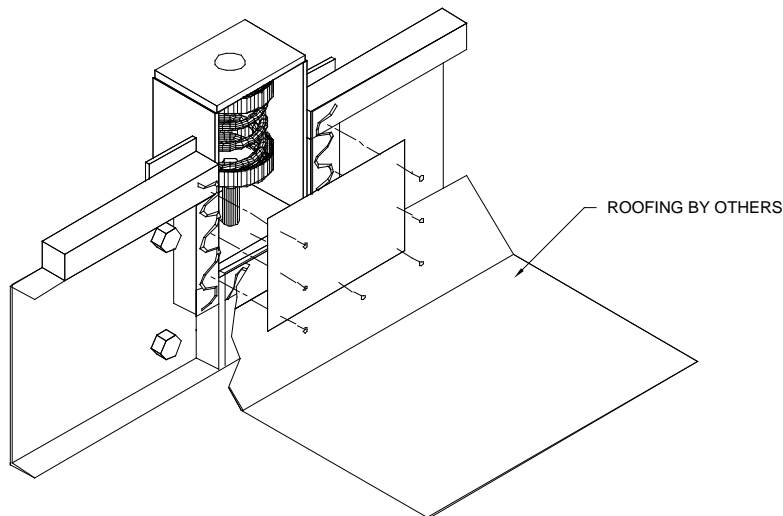

ESR Final Installation and Test

1. Add 1-1/2" insulation panels to the outside of the lower curb perimeter and flash to the roof structure (by others). If optional external insulation is supplied with the ESR, it should be installed using Anchor pins as shown below. If it is provided by others, follow the manufacturer's recommendation.

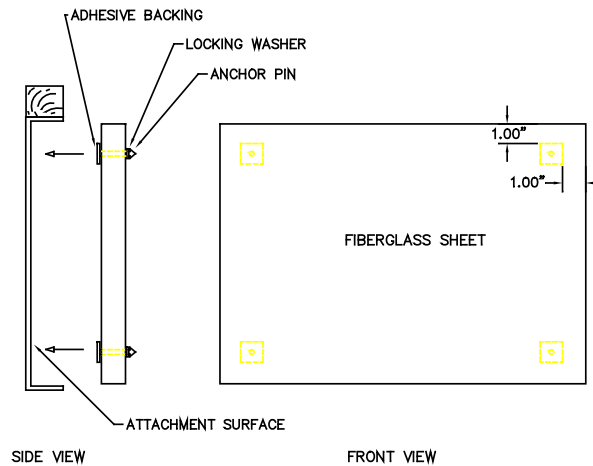

Procedure for Kinetics Provided Insulation

- A) Trim Fiberglass panels to desired size.
- B) Press a minimum of 4 anchor pins (1 per corner) through the fiberglass sheet, locating approximately 1" in from the corners and secure them with locking washers.
- C) For 6 to 8 ft long panels, 8 anchor pins (4 top and 4 bottom) should be used. For 4 to 6 ft long panels, 6 anchor pins (3 top and 3 bottom) should be used and for under 4 ft long panels, 4 pins are sufficient.
- D) Clean the metal surface and be sure it is free of dirt, oil and water.
- E) Peel the cover off the adhesive backed mounting plate and place the sheets against the metal perimeter panels and press them firmly to anchor the pins.

2. Flash the curb into the roof in a normal fashion. Note: If later access to the springs is desired, the flashing should terminate under the edge of the access covers for the spring coils and the access covers must be appropriately sealed to ensure watertight integrity.

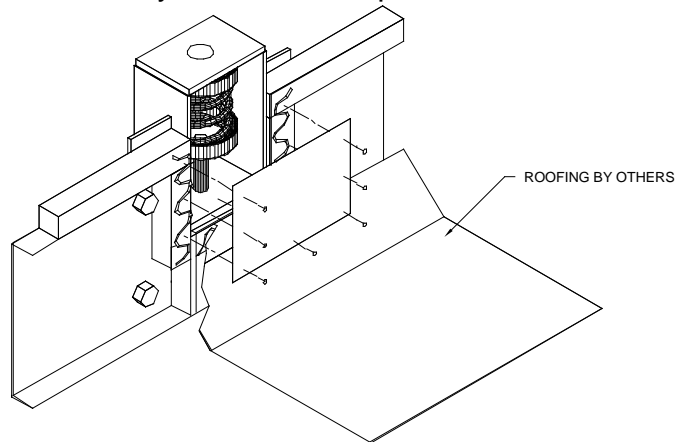

3. Attach the bottom edge of the EPDM weather seal to the wood



KINETICS NOISE CONTROL, INC
6300 IRELAN PLACE
DUBLIN, OHIO 43017
Ph 614-889-0480, FAX 614-889-0540

nailer on the curb (overlapping the roof flashing) and secure it 24" OC using the wood screws provided. (At the spring access coverplate location, the EPDM weather seal can be connected using self-tapping sheet metal screws.

4. After completing the connection, the excess weather seal can be trimmed.
5. Once the installation is complete, before the lifting equipment is permitted to leave the site and before interior ceiling tiles or other water damageable items are installed, spray the unit and ESR base with water to check for and correct any leaks.