



**NOISEBLOCK™** Modular Panel Enclosure Systems  
Commercial | Industrial | Environmental



# NOISEBLOCK™ Panel Systems: Commercial, Industrial, and Environmental Applications

Noise control in commercial, industrial, or environmental systems is an important element of the design process. Whether it is to comply with municipal ordinances, conform to OSHA standards or to achieve occupant comfort, designing a system to the required noise level takes knowledge and experience. For over 55 years **KINETICS NOISE CONTROL, INC.** has been delivering noise control solutions to meet the needs of many industries.

**KINETICS** designs and manufactures a complete line of modular engineered systems incorporating the **NOISEBLOCK™** acoustic panel. This double-walled acoustic panel can be quickly and easily assembled into a variety of plenum, equipment enclosure, or process enclosure configurations; and are designed to provide a high level of sound absorption and transmission loss.

**KINETICS** offers a complete design and engineering service, including acoustic, structural and ventilation provisions. This allows us to deliver custom, cost effective products and solutions that will fit your system and meet your needs.

## Commercial Applications

---

The mitigation of noise from heating and cooling systems in modern commercial projects is an important aspect in any building design. **KINETICS** engineers and manufactures complete pressurized plenum enclosures for a wide array of HVAC installations. **NOISEBLOCK™** pressurized plenums are designed to provide effective noise control, structural integrity, along with full access for maintenance and inspection.

### Applications

- Built-up and Custom Air Handlers
- Double Wall Panel Duct
- Fan Enclosures
- HVAC Mixing Plenums
- Mechanical Equipment
- Relief / Outside Air Plenums
- Supply / Return Plenums



Field Assembled **NOISEBLOCK™** AHU Casing



## Industrial Applications

---



In-Plant **NOISEBLOCK™** Equipment Enclosure

---

Worker safety has taken on increasing importance for industrial facilities, and as such, noise reduction initiatives have become an essential goal of the industry. Whether it is to comply with increasingly strict OSHA regulations, or to reduce hearing loss claims against an insurer, worker safety is now in the forefront. **NOISEBLOCK™** enclosures are a key design element in bringing industrial, process and manufacturing facilities to safer noise levels and to help make a better work environment for all involved.

### Applications

- Backup/Constant Power Generators
- Compressors
- In-Plant Offices
- Manufacturing Equipment
- Paint Booths
- Positive Displacement Blowers
- Processes
- Test Chambers
- Vacuum Blowers
- Ventilation Fans
- Pumps
- Saws
- Punch Presses

## Environmental Applications

---



Process Blower **NOISEBLOCK™** Enclosure

---

With residential areas encroaching on industrial and commercial areas, environmental noise is a main concern for communities. It is common for commercial and industrial facilities to have mechanical or process equipment located outside of the building, where the noise generated from this equipment was once not a concern, it is now. To mitigate outside noise sources a partial or complete **NOISEBLOCK™** panel enclosure can be used. **KINETICS** engineers their enclosures with special design considerations for outdoor use, such as wind and snow loading, weather protection, proper roof design to avoid water pooling, waterproofing, and the use of special materials. **KINETICS** can provide a complete engineered system to account for all acoustic, structural and ventilation aspects.

### Applications

- Air-Cooled Chillers
- Cooling Towers
- LNG Terminal Process Equipment
- Wastewater Treatment Plant Process Blowers
- Generators
- Fans
- Blowers

# NOISEBLOCK™ Panel Types

---

**Type STL acoustic panels** are fabricated of various thicknesses and materials depending on the level of noise control required for a particular application. Standard **KINETICS NOISEBLOCK™** type STL panels are fabricated with an outer solid shell of 18 gage and inner perforated shell of 22 gage steel. Panels are stiffened with 18 gage internal channels and edge rails. The acoustic grade fill is 2.5 to 6 pcf long strand fiberglass or mineral wool, depending on the application, are inert, mildew resistant, vermin proof and incombustible. Standard panels are 4" thick, but optional 2" and 6" panels are available to meet special requirements.

**Type HTL acoustic panels** are designed for applications where a higher transmission loss is required. Standard **KINETICS** type HTL panels are fabricated with an outer solid shell of 16 gage and inner perforated shell of 22 gage steel with a high mass septum added for increased acoustic performance. Panels are stiffened with 18 gage internal channels and edge rails. The acoustic grade fill is 2.5 to 6 pcf long strand fiberglass or mineral wool depending on the application and are inert, mildew resistant, vermin proof and incombustible. Panels are available in 4" or 6" thickness.

## Materials

---

Outer and inner shell materials are available in standard galvanized steel, Type G90, mill phosphatized (satin) finish galvanized steel (readily paintable), stainless steel, Types 304 and 316, aluminum and aluminized steel. Standard material gages for solid outer shell are 18 ga. and 16 ga., perforated (23% open area) inner shell is 22 gage. Septum panels and panels with solid outer and inner shells are available. Factory applied powder-coat finish is available as an additional option.

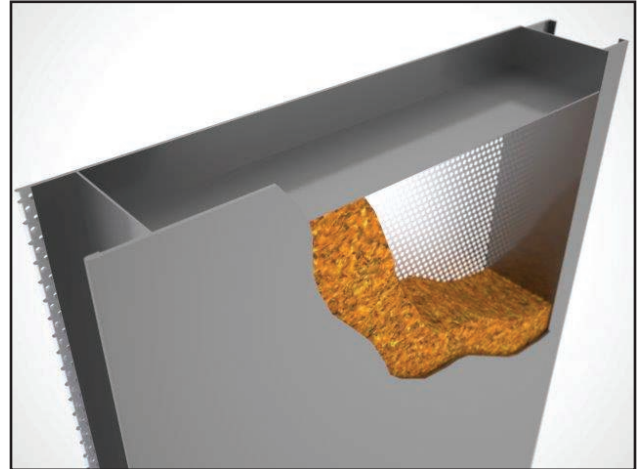

Typical STL panel detail: solid outer shell, media, and perforated inner shell.



Typical groove and tongue (GT) panel joint

All internal sound absorbing media used in **NOISEBLOCK™** panels meet the requirements of NFPA-90A and surface burning characteristics per ASTM E84, with maximum flame spread rating of 25 and smoke developed rating of 50. Other media are available offering more stringent flame spread index and smoke developed index. The media is available both unlined, lined or bagged using a specialized film or cloth barrier and acoustic spacer. The insulation is under compression so as not to allow settling of acoustic media within the panel.

## Standard Panel Dimensions

---

**NOISEBLOCK™** acoustic panels are available in standard designated widths of 21.625" and 45.625", and standard lengths up to 144". Other width and lengths are available by special order. Most **NOISEBLOCK™** enclosure and plenum systems incorporate as many standard panels as possible and then finished with non standard panels. For pressurized plenum systems the maximum panel width is determined by the internal operating static pressure (positive or negative), simply supported panel span and allowable panel deflection.

## NOISEBLOCK™ Panel Joint

---

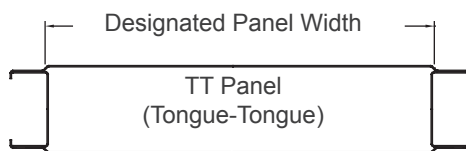
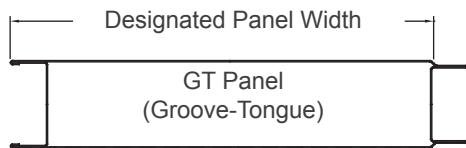
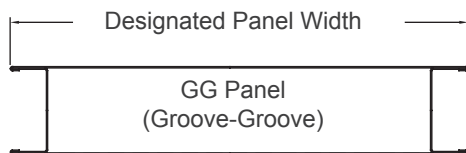

Panel connection style and width reference. Tongue and groove connections are standard for 16 gage shell and lighter. Heavier gages incorporate H-joiners.

## Accessories

---

**NOISEBLOCK™** acoustic panel systems offer many accessory items: forced or passive silenced ventilation systems, windows, single and double leaf access doors, removable panel wall and roof sections, structural steel components, and factory painting.

## Silenced Ventilation Systems

---

**KINETICS** engineers will work with you to properly design wall or roof mounted, silenced forced/passive ventilation systems. **KINETICS** ensures the enclosed equipment or process is properly ventilated as to prevent overheating. **KINETICS** does this by choosing from our expansive product line of circular (VCS), rectangular straight (VRS) and elbow (VES) absorptive

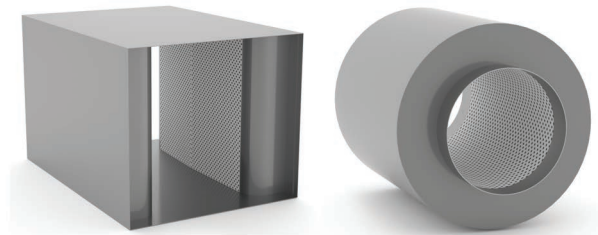

or reactive silencers and fixed-blade acoustic louvers (VAL/VAC/VPL). All are backed by independent testing per ASTM E477 and/or ASTM E90 in NVLAP accredited laboratories.



# Acoustic Performance Data

---

**NOISEBLOCK** panel acoustic performance is backed by independent testing in a NVLAP accredited laboratory. When tested in accordance with *ASTM C423, Standard Method of Test for Sound Absorption of Acoustic Materials in Reverberant Rooms*, the panel assembly shall have the following minimum airborne sound absorption:

Model	Construction <sup>3</sup>	Sound Absorption						NRC <sup>4</sup>
		125	250	500	1000	2000	4000	
STL-2 <sup>1</sup>	18 ga. solid / 22 ga. perforated	0.15	0.66	1.07	1.06	0.97	0.86	0.95
STL-2 <sup>1</sup>	16 ga. solid / 22 ga. perforated	0.15	0.66	1.07	1.06	0.97	0.86	0.95
STL-4 <sup>2</sup>	18 ga. solid / 22 ga. perforated	0.60	1.13	1.12	1.09	1.03	0.91	1.00
STL-4 <sup>2</sup>	16 ga. solid / 22 ga. perforated	0.60	1.13	1.12	1.09	1.03	0.91	1.00
HTL-4 <sup>2</sup>	16 ga. solid / 22 ga. perforated + septum	0.60	1.13	1.12	1.09	1.03	0.91	1.00

When tested in accordance with *ASTM E90, Standard Recommended Practice for Laboratory Measurement of Airborne Sound Transmission Loss of Building Partitions*, the panel assembly shall have the following minimum airborne sound transmission loss:

Model	Construction <sup>3</sup>	Transmission Loss, dB						STC <sup>5</sup>
		125	250	500	1000	2000	4000	
STL-2 <sup>1</sup>	18 ga. solid / 22 ga. perforated	17	23	34	47	55	57	37
STL-2 <sup>1</sup>	16 ga. solid / 22 ga. perforated	19	25	35	48	56	60	39
STL-4 <sup>2</sup>	18 ga. solid / 22 ga. perforated	21	28	39	48	56	58	40
STL-4 <sup>2</sup>	16 ga. solid / 22 ga. perforated	24	32	41	51	60	66	43
HTL-4 <sup>2</sup>	16 ga. solid / 22 ga. perforated + septum	27	34	48	61	66	70	48

The acoustic performance of **NOISEBLOCK** panel systems is not degraded through prolonged exposure to noise, vibration, pressure differential, dampness, wind, rain or snow.

<sup>1</sup> (2) = 2-inch thickness

<sup>2</sup> (4) = 4-inch thickness

<sup>3</sup> solid inner skin available

<sup>4</sup> Noise Reduction Coefficient (NRC) is the average of coefficients at 250, 500, 1K and 2K Hz, expressed in the nearest integral multiple of 0.05.

<sup>5</sup> Sound Transmission Class (STC) is determined by comparing test data with a set of standard STC contours as described in *ASTM E413, Standard Classification for Determination of Sound Transmission Class*.

## Achievable Noise Reduction

---

**NOISEBLOCK™** enclosure systems offer typical noise reductions of 20-35 dBA. Special custom systems incorporating heavier (thicker gage) panel shell, thicker panels or an enclosure within an enclosure are available to achieve higher levels of noise reduction.

# Thermal Performance

---

The insulation materials used in **NOISEBLOCK™** panels at 75°F have maximum thermal conductance values of 0.06 BTU/hr-ft<sup>2</sup>-°F (4" thick) and 0.12 BTU/hr-ft<sup>2</sup>-°F (2 inch thick). Thermal resistance values are R17 (4" thick) and R8 (2" thick). Other insulation materials yielding higher thermal performance values are available.

## Windows

---

Observation windows are available as double-pane, wire reinforced, or tempered safety glass. The windows are held in place with a flexible acoustic, airtight seal and separated by an airspace of the same thickness as the **NOISEBLOCK™** panel. Depending on window size it can be factory installed or shipped and field installed. High STC rated windows are available where maximum noise control is required.

## Doors

---

A complete line of single and double leaf **NOISEBLOCK™** access doors are available in various sizes and can be incorporated to meet a variety of needs such as personnel and machinery access. Single and double leaf access doors are available with industrial grade strap hinges (swing right/left, in/out) and panic/passage hardware (keyed locks or sliding hardware are available as an option). The maximum single leaf door size is 48" wide x 96" high and the maximum double leaf door size is 144" wide x 144" high. Door thicknesses match adjacent panel thickness, construction, and acoustic performance.

Pressurized plenum single leaf doors are available in various sizes and have acoustic edge and bottom seals, doors are factory pre-hung, insulated and equipped with 2 or 3 strap hinges with Ventlok latches. (zinc and aluminum non-corrosive alloy). Double-pane, wire reinforced view ports are an available option.

## Removable Panels

---

**NOISEBLOCK™** removable access panels for walls and roofs can be located and sized as required for easy access to interior equipment for maintenance, service, or repair. The construction of removable panels is the same as the surrounding panels. Depending on the size and frequency of use, removable panels incorporate Ventlock latches or bolted connections. Roof access panels for outdoor applications can be designed for sloped roofs or can incorporate a raised curb for flat roofs. Lifting lugs and special flashing are included as required.

## Structural Steel Components

---

Structural steel components and welded assemblies are designed for either field welding or bolt together assembly. Standard structural items are shipped with one factory coat of primer for protection during shipping. **KINETICS** can supply structural items with hot-dip galvanized coated finish or factory painted with either a wet paint or powder-coat finish depending on size and specification.



# Standard Construction and Connection Details

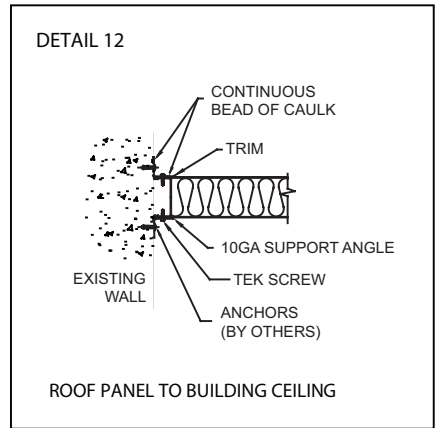
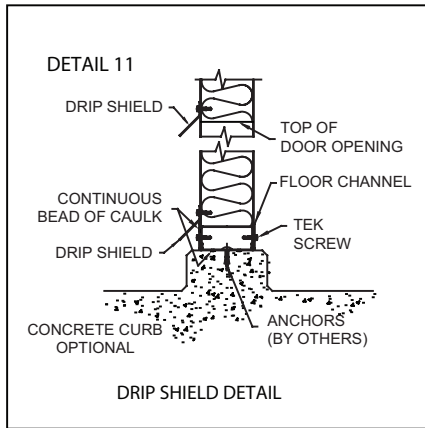
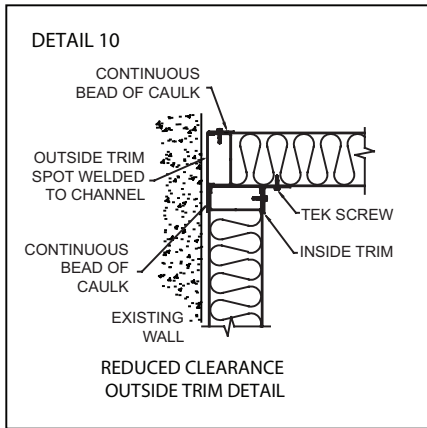
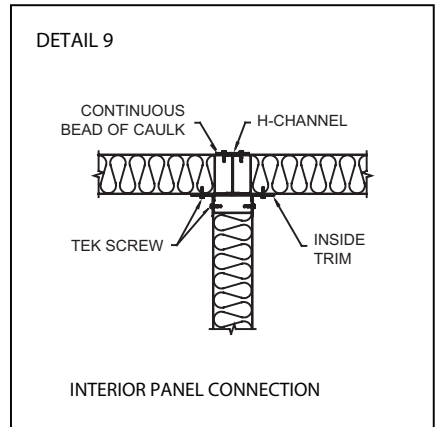
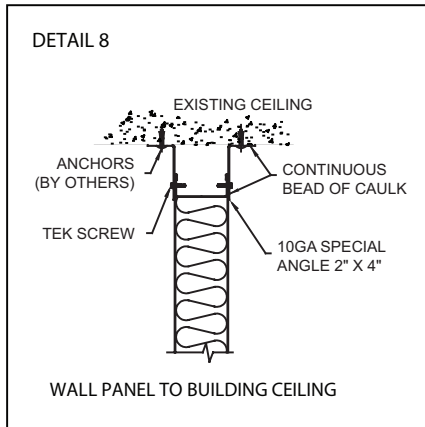
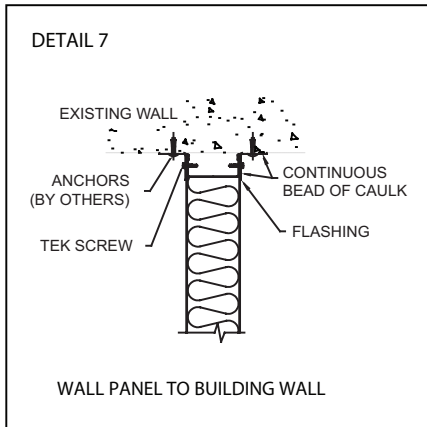
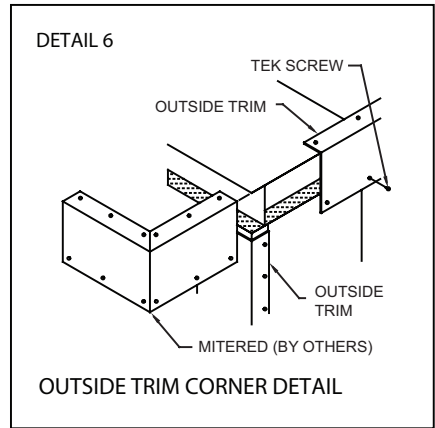
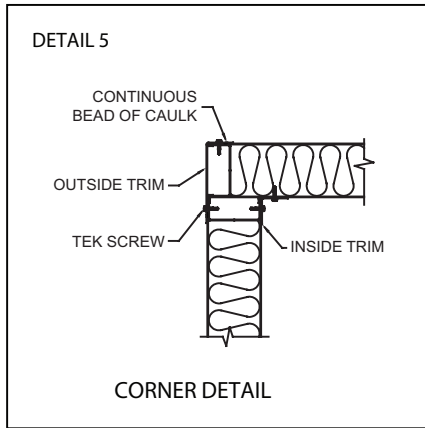
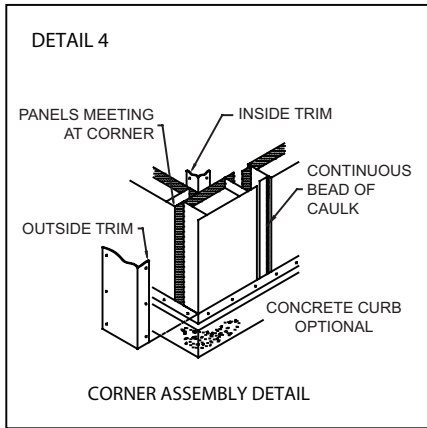
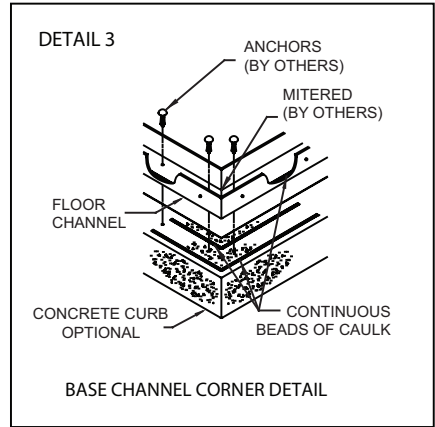
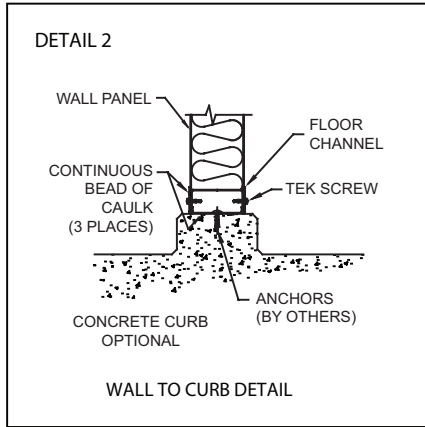
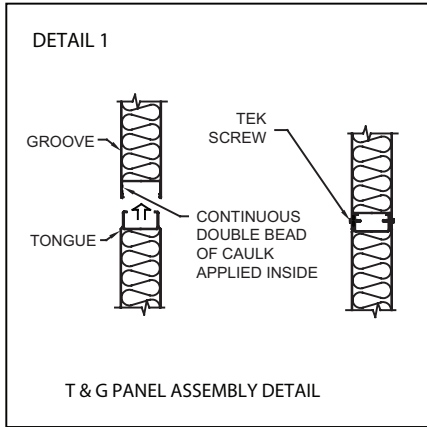



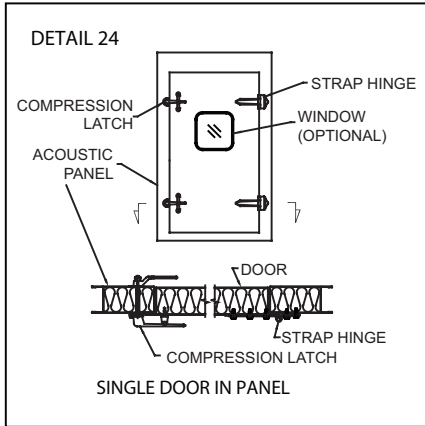
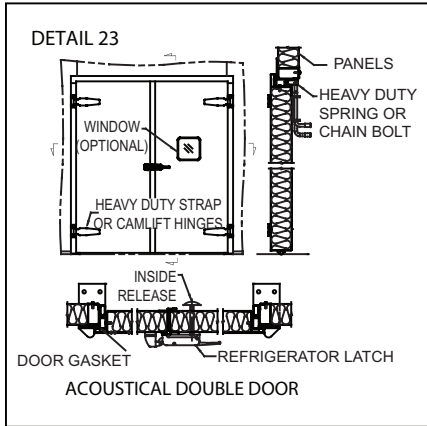
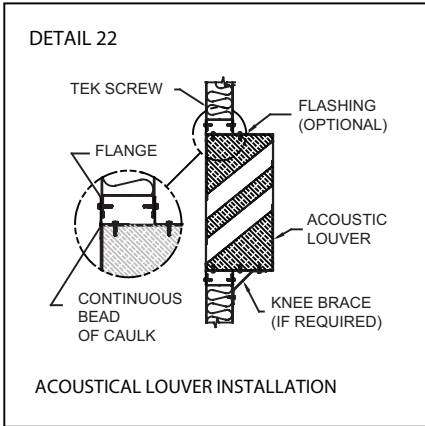
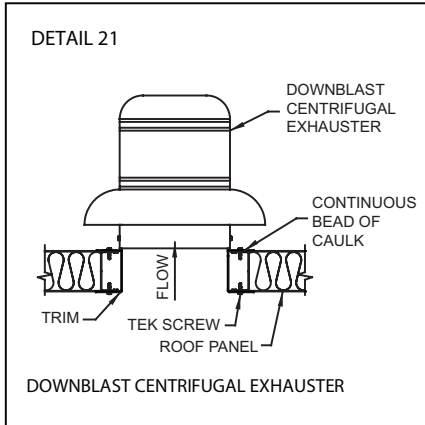
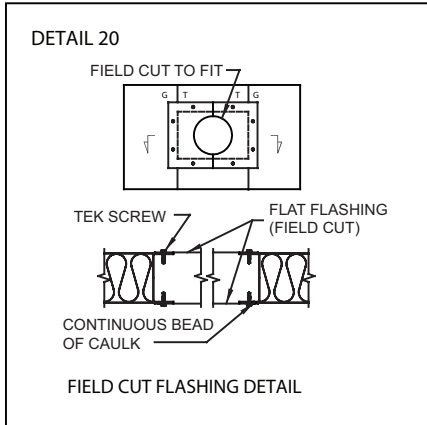
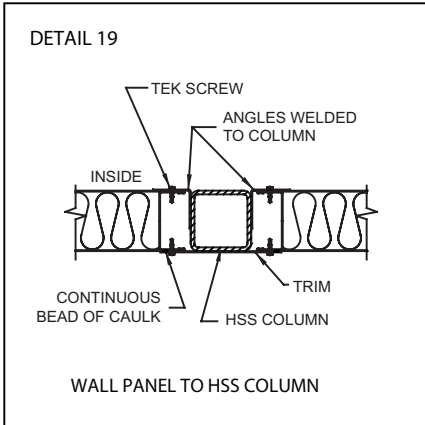
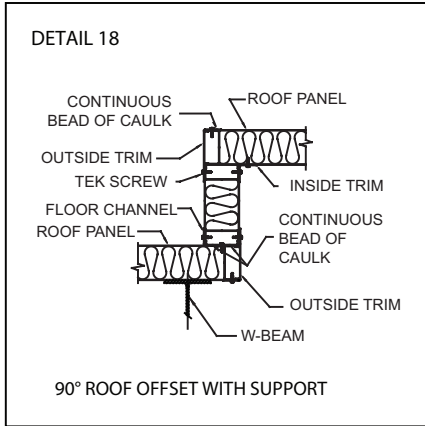
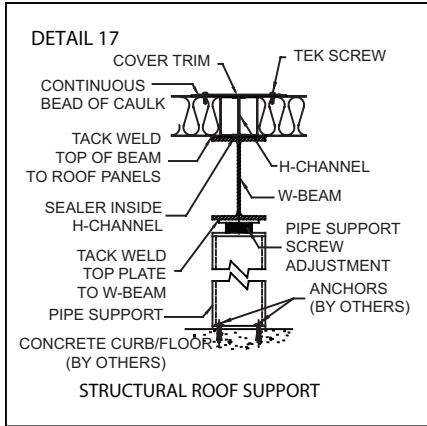
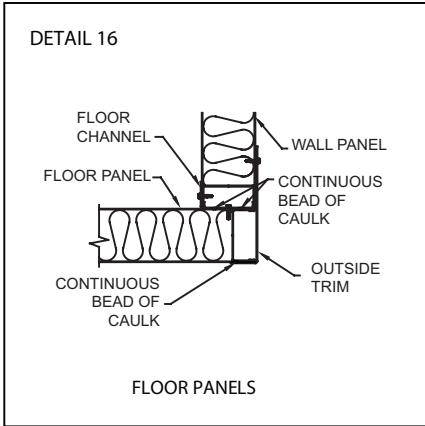
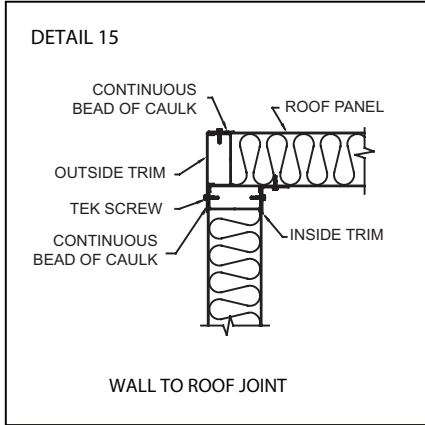
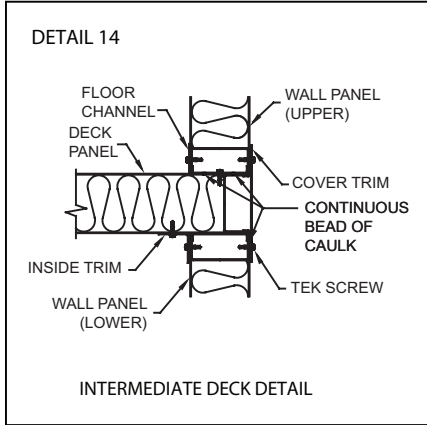
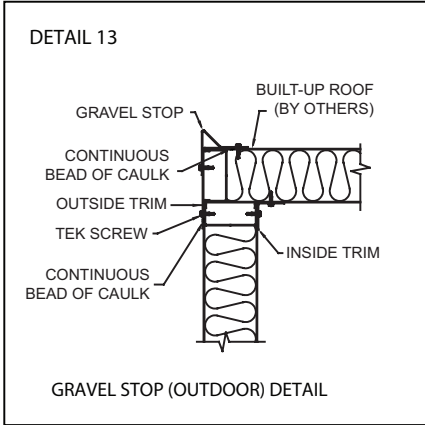

## Structural Performance

---

**NOISEBLOCK™** acoustic panel enclosures and plenum systems are structurally designed for internal and external loading ( $\pm$  internal static pressure, wind loads, snow loads, live and dead loads as well as seismic) per industry standards following the applicable IBC building codes. Available options include copies of the structural steel calculations and PE stamp. **KINETICS** engineering group uses the latest AutoCAD software and can incorporate your equipment or system AutoCAD layout into our submittals to assure proper clearances and access locations.

## Installation Guidelines

---

**KINETICS** supplies complete AutoCAD submittal, piece-marked installation drawings and bill of materials which correspond to the factory piece-marked panel system components. This piece-marking notation allows for easy installation of any system by referencing the numbers associated on the project specific assembly drawings and details. Typical enclosure and plenum systems incorporate six standard components, **NOISEBLOCK™** tongue and groove panels, base channel, inside and outside trim pieces, fasteners, sealant and door(s).

## Installation Planning Tips

---

1. Review the **KINETICS** supplied job specific, piece-marked, installation drawings and compare against the supplied bill of materials.
2. Prior to delivery of product, clear an area near where the panels are to be installed so they can be conveniently stored. To save time and labor move panels directly from the truck to this area. Make sure the necessary material handling equipment is available, including lifts for unloading and carts for moving panels across the floor to the installation site.
3. Near the installation area stack the panels on end and lengthwise with piece marks exposed. This will save time from moving and restacking panels as the enclosure is installed. If more than one enclosure is involved separate panels by drawing number as referenced on the bill of materials.
4. Typical tools and equipment required for successful installation are: ladder, extension cord, lifts, portable lighting, masonry and metal drill, metal cutting saw, tape measure, caulking gun, come a long.
5. Summary of Installation:
  - Locate base channel
  - Set corner panels
  - Install wall, partition and door panels
  - Add wall trim inside and outside
  - Install structural components (if required)
  - Add roof panels
  - Add roof trim inside and outside
  - Complete enclosure

# Packaging

---

**NOISEBLOCK™** panel systems are knocked-down (unassembled), standard palletized, banded and shrink wrapped before shipping. All panels, trim items including optional items are piece-marked to correspond to piece-marked installation drawings and details supplied with every order. Inside and outside trim are supplied in standard 10'-0" lengths to be field cut to required lengths. Standard shipments are sent in a closed trailer but flatbed shipments are available per special request.



Standard Skid Packaging



Export Crate Packaging

# Finish

---

NOISEBLOCK panel systems are available factory powder-coat finish per selection of POWDURA® RAL Series Super Durable TGIC FREE Polyester Powder Coatings, color matching or mill/unpainted.

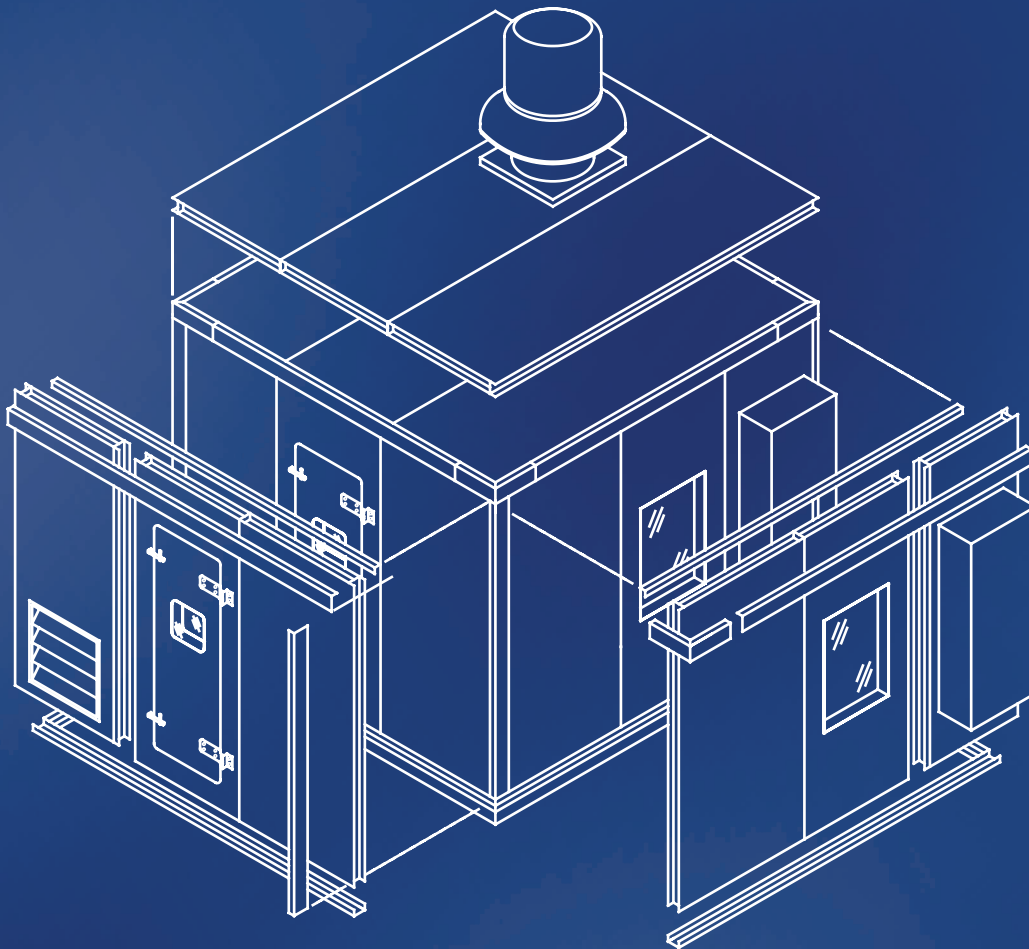

[kineticsnoise.com/noiseblock](https://www.kineticsnoise.com/noiseblock)  
sales@kineticsnoise.com  
1-800-959-1229