



# KINETICS®

## KINFLEX™ Flexible Connectors

### Description

KINFLEX Flexible Connectors prevent stresses due to expansion and contraction, isolate against the transfer of noise and vibration, and compensate for misalignment.

KINFLEX connectors absorb the continuing movement experienced in piping systems because of varying ambient temperatures, differences in temperature of materials being handled, and differences in composition. The danger of buckling or pulling apart and resulting maintenance costs are eliminated.

KINFLEX connectors reduce objectionable noise and vibration in piping systems connected to pumps, compressors, and similar pulsating equipment. The transmission of noise and vibration tends to reduce the efficiency of adjacent equipment as well as impairing the working conditions in offices and factories.

Settlement, load stresses, and wearing of parts frequently cause piping and mechanical equipment to move out of normal alignment. KINFLEX connectors compensate for these lateral, torsional, and angular movements.

### Applications

**Air Conditioning, Heating, and Ventilating Systems:** KINFLEX Flexible Connectors eliminate stresses caused by changes in temperature and piping misalignment, as well as reduce the transmission of noise and vibration. They are used on both hot and chilled water circulation lines, suction and discharge sides of pumps, and header connections.

**Industrial:** One of the most significant uses for KINFLEX connectors is in industrial piping installations to compensate for the thermal expansion and contraction of the pipe.

**Power Plants:** Because of the ability of the KINFLEX connectors to adjust to pipe misalignment, they can be

used in power plants for condenser connections, auxiliary exhaust lines, and connections to air ejectors.

**Marine Systems:** KINFLEX connectors isolate marine systems against the transmission of noise and vibration and eliminate the destructive action of electrolysis. They are used on suction and discharge sides of circulating water-cooling systems and air intake lines on diesel engines.

**Sewage Treatment Plants and Pollution Control:** KINFLEX connectors are used extensively in sewage water treatment-plants and pollution-control systems.

**Control Rod Applications:** Optional Control rod assemblies are designed to absorb static pressure thrust developed at the connector, thus minimizing possible failure of the connector or damage to the equipment. When used in this manner, control unit assemblies are an additional safety factor, minimizing possible failure of the expansion joint or damage to the equipment.

- 1. Anchored Systems:** Control rod assemblies are not required in piping systems that are anchored on both sides of the connector provided piping movements are within the rated movements.
- 2. Unanchored Systems:** Control rod assemblies are always recommended in unanchored systems and when the maximum pressure and movement exceeds the rated limit.
- 3. Spring-Mounted Equipment:** Control rod assemblies are always recommended for spring-mounted equipment when the maximum pressure and movement exceed the rated limit.

# Neoprene Flexible Connectors

More models available. Visit [KineticsNoise.com/KINFLEX](http://KineticsNoise.com/KINFLEX) to see KINETICS complete line of flexible connectors.

## KINFLEX FC Single-Sphere Connector with Floating Flanges

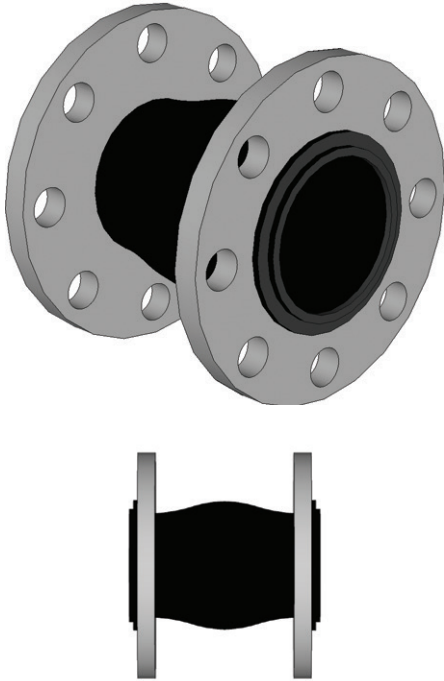

Allowable Movements in Operation

Size-A In. (mm)	Length-L In. (mm)	Axial Compression	Axial Elongation	Transverse Movement	Angular	Weight Lbs. (kg)
		In. (mm)	In. (mm)	In. (mm)	Deflection	
1 (25)	6 (152)	½ (13)	¾ (9)	±½ (13)	15°	4 (1.8)
1-¼ (32)	6 (152)	½ (13)	¾ (9)	±½ (13)	15°	5 (2.3)
1-½ (38)	6 (152)	½ (13)	¾ (9)	±½ (13)	15°	6 (2.8)
2 (50)	6 (152)	½ (13)	¾ (9)	±½ (13)	15°	9 (4.0)
2-½ (63)	6 (152)	½ (13)	¾ (9)	±½ (13)	15°	12 (5.6)
3 (75)	6 (152)	½ (13)	¾ (9)	±½ (13)	15°	14 (6.4)
4 (100)	6 (152)	¾ (19)	½ (13)	±½ (13)	15°	18 (8.3)
5 (127)	6 (152)	¾ (19)	½ (13)	±½ (13)	15°	23 (10.4)
6 (152)	6 (152)	¾ (19)	½ (13)	±½ (13)	15°	27 (12.2)
8 (203)	6 (152)	¾ (19)	½ (13)	±½ (13)	15°	41 (18.4)
10 (254)	8 (203)	1 (25)	¾ (16)	±¾ (19)	15°	57 (25.6)
12 (305)	8 (203)	1 (25)	¾ (16)	±¾ (19)	15°	83 (37.7)
14 (356)	8 (203)	1 (25)	¾ (16)	±¾ (19)	15°	115 (52.3)
16 (406)	8 (203)	1 (25)	¾ (16)	±¾ (19)	15°	165 (75.0)
18 (457)	8 (203)	1 (25)	¾ (16)	±¾ (19)	15°	168 (76.4)
20 (508)	8 (203)	1 (25)	¾ (16)	±¾ (19)	15°	170 (77.3)
24 (610)	10 (254)	1 (25)	¾ (16)	±¾ (19)	15°	255 (116.0)

<b>Operating Conditions</b>	1-½" - 12" (38 mm - 305 mm)	14" - 24" (356 mm - 610 mm)
*Operating Pressure	225 psig (16 kg/cm <sup>2</sup> )	125 psig (8.6 kg/cm <sup>2</sup> )
*Burst Pressure	900 psig (62 kg/cm <sup>2</sup> )	500 psig (34 kg/cm <sup>2</sup> )
*Vacuum Rating	26" (600 mm) Hg	
*Temperature	14°F to 225°F (-10°C to 107°C)	
*Applicable Fluids	Water, warm water, seawater, weak acids, alkalies, compressed air, etc.	

## KINFLEX FTC Twin-Sphere Connector with Floating Flanges

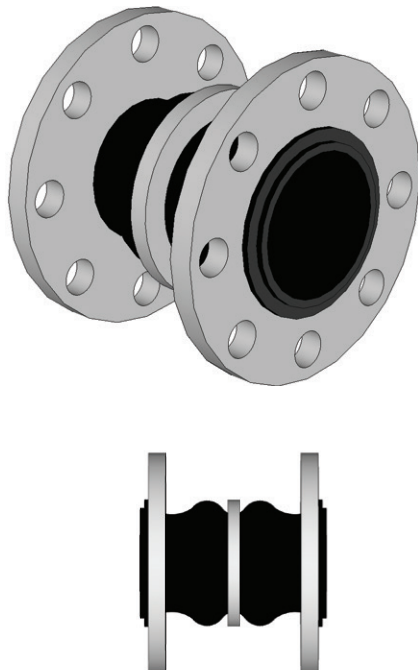

Allowable Movements in Operation

Size-A In. (mm)	Length-L In. (mm)	Axial Compression	Axial Elongation	Transverse Movement	Angular	Weight Lbs. (kg)
		In. (mm)	In. (mm)	In. (mm)	Deflection	
1-¼ (32)	7 (118)	2-¼ (52)	1-¼ (27)	1-¾ (45)	40°	6 (2.8)
1-½ (38)	7 (118)	2-¼ (52)	1-¼ (27)	1-¾ (45)	40°	7 (3.1)
2 (50)	7 (118)	2-¼ (52)	1-¼ (27)	1-¾ (45)	40°	9 (4.1)
2-½ (63)	7 (118)	2-¼ (52)	1-¼ (27)	1-¾ (45)	40°	14 (6.4)
3 (75)	7 (118)	2-¼ (52)	1-¼ (27)	1-¾ (45)	40°	15 (6.5)
4 (100)	9 (229)	2-¼ (52)	1-¾ (30)	1-½ (40)	35°	21 (9.5)
5 (127)	9 (229)	2-¼ (52)	1-¾ (30)	1-½ (40)	35°	25 (11.1)
6 (152)	9 (229)	2-¼ (52)	1-¾ (30)	1-½ (40)	35°	30 (13.4)
8 (203)	13 (330)	2-¾ (65)	1-½ (29)	1-¾ (35)	30°	44 (19.9)
10 (254)	13 (330)	2-¾ (65)	1-½ (29)	1-¾ (35)	30°	64 (29.1)
12 (305)	13 (330)	2-¾ (65)	1-½ (29)	1-¾ (35)	30°	95 (43.2)
14 (356)	13-¾ (349)	1-¾ (45)	1-¾ (30)	1-¾ (30)	20°	135 (61.2)
16 (406)	13-¾ (349)	1-¾ (45)	1-¾ (30)	1-¾ (30)	20°	175 (79.4)
18 (457)	13-¾ (349)	1-¾ (45)	1-¾ (30)	1-¾ (30)	20°	181 (82.1)
20 (508)	13-¾ (349)	1-¾ (45)	1-¾ (30)	1-¾ (30)	20°	185 (83.9)
24 (610)	13-¾ (349)	1-¾ (45)	1-¾ (30)	1-¾ (30)	20°	295 (133.8)

<b>Operating Conditions</b>	1-½" - 12" (38 mm - 305 mm)
*Operating Pressure	225 psig (16 kg/cm <sup>2</sup> )
*Burst Pressure	900 psig (62 kg/cm <sup>2</sup> )
*Vacuum Rating	26" (600 mm) Hg
*Temperature	14°F to 225°F (-10°C to 107°C)
*Applicable Fluids	Water, warm water, seawater, weak acids, alkalies, compressed air, etc.

# Seismic V-Loops



Kinetics seismic V-loops solve the problems of pipe motion caused by thermal pipe growth and the movements associated with seismic activity. Benefits of the seismic V-loops include limited amount of space required for installation and the ability to hold in heat compared to traditional large pipe loops. Another benefit is V-Loops do not introduce thrust loads on the piping systems whereas metal bellows and rubber expansion joints impose significant anchor loads due to the effects of static pressure thrust.

Construction of the V-loop is unique in the fact that it creates a flexible product that does not expand when pressurized. They can be designed in nested configurations with relatively tight centering. Standard installation is in horizontal pipe runs with the V-loop elbow pointing straight down. The use of an eyelet can be used for installations outside of the standard installation. Construction of the V-Loop can be manufactured with a variety of end fitting and also copper or stainless steel braided material.

## V-Loop Copper Sweat Ends

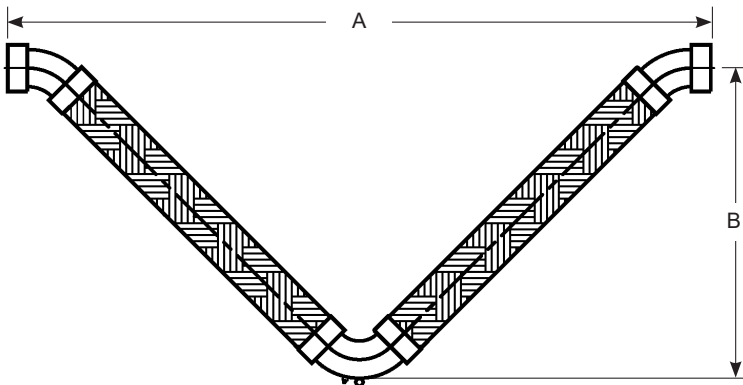

**Materials of Construction:** **End Fittings:** Copper Female Sweat  
**Hose & Braid:** Single Braided Bronze  
**90° Elbow:** Copper  
**180° Return:** Copper

### V-Loops Cooper Sweat Ends: 4" Movement

Also available as 2" Movement, 2" Movement NSF-372 Compliant, and 3" Movement.

Pipe Size NPS	Axial	A	B	Working Pressure (PSIG)	Spring Force LBS*
1/2"	+/- 4"	26.50"	12.50"	706	45
3/4"	+/- 4"	30.00"	14.00"	577	47
1"	+/- 4"	31.75"	14.00"	470	53
1-1/4"	+/- 4"	34.50"	16.00"	361	66
1-1/2"	+/- 4"	36.00"	16.50"	329	70
2"	+/- 4"	40.25"	18.50"	317	78
2-1/2"	+/- 4"	45.25"	20.25"	272	83
3"	+/- 4"	51.50"	23.50"	201	90
4"	+/- 4"	58.50"	26.50"	142	120

\*Spring force: These values reflect that total force required to move the V-Loop it's full rated movement for 150 PSI @ 70° F.

## V-Loop Threaded Ends

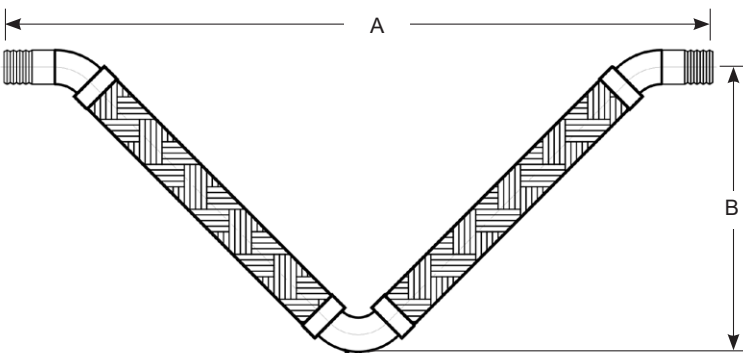

**Materials of Construction:** **End Fittings:** Carbon Steel Threaded Ends  
**Hose & Braid:** Stainless Steel  
**90° Elbow:** Carbon Steel  
**180° Return:** Carbon Steel

### S/S V-Loops Threaded Ends: 4" Movement

Also available in Copper or Stainless Steel as 2" and 3" Movement.

Pipe Size NPS	A	B	Approx. Spring Force**	Working Pressure (PSIG)	Max. Test Pressure (PSIG)
1/2"	28.50"	12.25"	75 lbs	1335	2003
3/4"	30.75"	13.25"	82 lbs	1135	1703
1"	34.50"	14.50"	86 lbs	795	1193
1-1/4"	37.00"	15.50"	93 lbs	610	915
1-1/2"	39.25"	16.50"	127 lbs	530	795
2"	44.00"	18.50"	214 lbs	516	774
2-1/2"	48.00"	22.75"	228 lbs	395	593
3"	55.25"	25.50"	312 lbs	385	578
4"	64.00"	25.50"	345 lbs	270	405

\*\*Total force necessary to accommodate full motion, calculated @ 150 PSIG. Note: Maximum operating temperature: 800° F



## V-Loop Grooved Ends

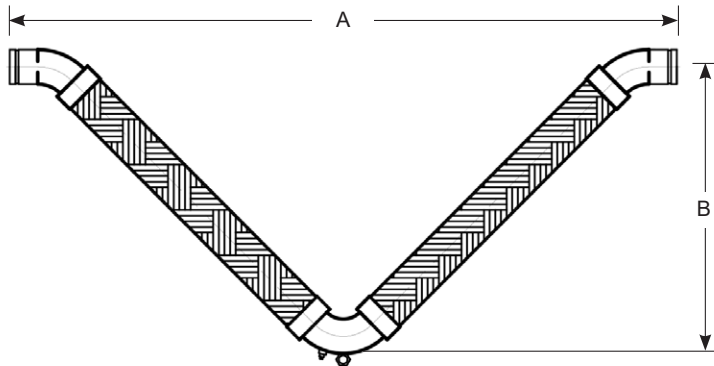

**Materials of Construction:** **End Fittings:** Groove Ends  
**Hose & Braid:** Stainless Steel  
**90° Elbow:** Carbon Steel  
**180° Return:** Carbon Steel

**S/S V-Loops Grooved Ends: 4" Movement**  
 Also available as Stainless Steel 2" Movement, 3" Movement, and Copper 4" Movement.

Pipe Size NPS	A	B	Approx. Spring Force**	Working Pressure (PSIG)	Max. Test Pressure (PSIG)
2"	46.50"	19.0"	82 lbs	516	774
2-1/2"	49.63"	20.0"	86 lbs	395	593
3"	55.75"	23.0"	93 lbs	385	578
4"	62.38"	36.0"	127 lbs	270	405
5"	70.88"	29.5"	214 lbs	225	337
6"	78.00"	32.5"	228 lbs	170	225
8"	91.50"	38.0"	312 lbs	235	353
10"	106.38"	44.0"	345 lbs	260	390
12"	118.38"	49.0"	399 lbs	160	240

\*\*Total force necessary to accommodate full motion, calculated @ 150 PSIG.

## V-Loop Flanged Ends

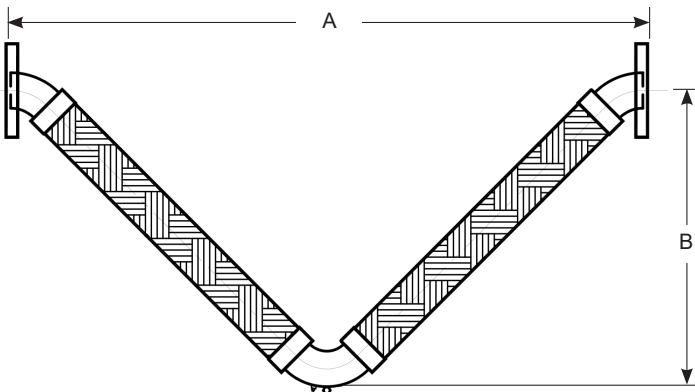

**Materials of Construction:** **End Fittings:** Plate Flanges  
**Hose & Braid:** Stainless Steel  
**90° Elbow:** Carbon Steel  
**180° Return:** Carbon Steel

**S/S V-Loops Flanged Ends: 4" Movement**  
 Available as Stainless Steel 2" Movement, and 3" Movement. Double Braided Option Available.

Pipe Size NPS	A	B	Approx. Spring Force**	Working Pressure (PSIG)	Max. Test Pressure (PSIG)
1-1/2"	35.75"	16.25"	75 lbs	530	795
2"	40.50"	18.75"	82 lbs	516	774
2-1/2"	43.50"	19.75"	86 lbs	395	593
3"	49.75"	22.75"	93 lbs	385	578
4"	56.50"	25.50"	127 lbs	270	405
5"	65.00"	29.00"	214 lbs	225	337
6"	72.00"	32.00"	228 lbs	170	225
8"	85.50"	37.50"	312 lbs	235	353
10"	100.25"	43.75"	345 lbs	260	390
12"	112.25"	48.50"	399 lbs	160	240

\*\*Total force necessary to accommodate full motion, calculated @ 150 PSIG. Note: Maximum operating temperature: 800° F. Other style flanges available.

## V-Loop Beveled Weld Ends

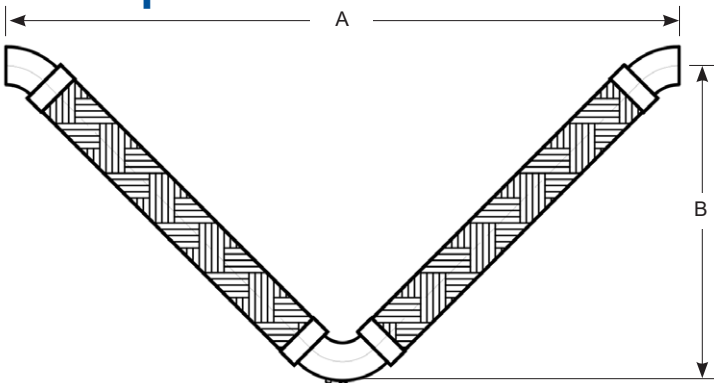

**Materials of Construction:** **End Fittings:** Beveled Weld Ends  
**Hose & Braid:** Stainless Steel  
**90° Elbow:** Carbon Steel  
**180° Return:** Carbon Steel

**V-Loops Beveled Weld Ends: 4" Movement**  
 Also available as Stainless Steel 2" Movement, and 3" Movement.

Pipe Size NPS	A	B	Approx. Spring Force**	Working Pressure (PSIG)	Max. Test Pressure (PSIG)
2"	40.00"	19.0"	82 lbs	516	774
2-1/2"	43.00"	20.0"	86 lbs	395	593
3"	49.25"	23.0"	93 lbs	385	578
4"	56.00"	26.0"	127 lbs	270	405
5"	64.50"	29.5"	214 lbs	225	337
6"	71.50"	32.5"	228 lbs	170	225
8"	85.00"	38.0"	312 lbs	235	353
10"	100.00"	44.0"	345 lbs	260	390
12"	112.00"	49.0"	399 lbs	160	240

\*\*Total force necessary to accommodate full motion, calculated @ 150 PSIG. Note: Maximum operating temperature: 800° F

# Metal Braided Flexible Connectors

Additional models available. Visit [KineticsNoise.com/KINFLEX](http://KineticsNoise.com/KINFLEX) to see KINETICS complete line of flexible connectors.

## KINFLEX BFMC-FFF - Flat Faced Flanges

KINFLEX BFMC-FFF features type 321 Stainless Steel Hose with type 304 Stainless Steel Outer Braid and 150# Carbon Steel Flat Faced Drilled Bolting Flanges



Size			Pipe Flange	Max. Lateral Offset		Working Pressure		Approx. Weight
I.D. x Length				Intermittent	Permanent	70° F	300° F	
in. (mm)	in. (mm)	in. (mm)	in. (mm)	in. (mm)	in. (mm)	PSI (BAR)	PSI (BAR)	lbs. / kg
2.00 (51)	x 9 (229)	0.68 (17)	0.125 (3)	0.375 (10)		455 (31)	400 (28)	9 / 4
2.50 (64)	x 9 (229)	0.75 (19)	0.125 (3)	0.375 (10)		345 (24)	303 (21)	13 / 6
3.00 (76)	x 9 (229)	0.88 (22)	0.125 (3)	0.375 (10)		289 (20)	254 (17)	15 / 7
4.00 (101)	x 9 (229)	0.88 (22)	0.125 (3)	0.375 (10)		300 (21)	264 (18)	18 / 8
5.00 (127)	x 11 (279)	0.88 (22)	0.125 (3)	0.375 (10)		220 (16)	193 (13)	25 / 11
6.00 (152)	x 11 (279)	1.00 (25)	0.125 (3)	0.375 (10)		200 (14)	176 (12)	28 / 13
8.00 (203)	x 12 (305)	1.06 (27)	0.125 (3)	0.375 (10)		190 (13)	167 (12)	52 / 24
10.0 (254)	x 13 (330)	1.06 (27)	0.125 (3)	0.375 (10)		165 (11)	145 (10)	65 / 29
12.0 (305)	x 14 (356)	1.12 (28)	0.125 (3)	0.375 (10)		125 (9)	110 (8)	105 / 48
14.0 (356)	x 14 (356)	1.12 (28)	0.125 (3)	0.375 (10)		105 (7)	92 (6)	115 / 25

## KINFLEX BFMC-MTE: Metal Threaded End

KINFLEX BFMC-MTE features a Bronze Hose with Bronze Outer Braid and Male NPT Carbon Steel Threaded End



Size			Pipe Flange	Max. Lateral Offset		Working Pressure		Approx. Weight
I.D. x Length				Intermittent	Permanent	70° F	300° F	
in. (mm)	in. (mm)	in. (mm)	in. (mm)	in. (mm)	in. (mm)	PSI (BAR)	PSI (BAR)	lbs. / kg
0.50 (13)	x 6.5 (165)	0.50 (13)	0.25 (6)	0.5 (13)		1200 (82.7)	1020 (70.3)	1.0 / 0.50
0.75 (19)	x 7.0 (178)	0.75 (19)	0.25 (6)	0.5 (13)		1034 (71.3)	879 (60.6)	1.0 / 0.50
1.00 (25)	x 8.0 (203)	1.00 (25)	0.25 (6)	0.5 (13)		796 (54.9)	677 (46.7)	1.0 / 0.50
1.25 (32)	x 8.5 (216)	1.25 (32)	0.25 (6)	0.5 (13)		600 (41.4)	510 (35.2)	2.0 / 0.90
1.50 (38)	x 9.0 (229)	1.50 (38)	0.25 (6)	0.5 (13)		551 (38.0)	468 (32.3)	3.5 / 1.60
2.00 (51)	x 10.5 (267)	2.00 (51)	0.25 (6)	0.5 (13)		557 (38.4)	473 (32.6)	5.0 / 2.30
2.50 (64)	x 12.0 (305)	2.50 (64)	0.25 (6)	0.5 (13)		387 (26.7)	329 (22.7)	7.0 / 3.20

## KINFLEX BFMC-GE: Grooved Ends

KINFLEX BFMC-GE features Type 321 Stainless Steel Hose with Type 304 Stainless Outer Braid and Carbon Steel Grooved Ends



Size			Pipe Flange	Max. Lateral Offset		Working Pressure		Approx. Weight
I.D. x Length				Intermittent	Permanent	70° F	300° F	
in. (mm)	in. (mm)	in. (mm)	in. (mm)	in. (mm)	in. (mm)	PSI (BAR)	PSI (BAR)	lbs. / kg
2.00 (51)	x 12 (305)	2.00 (51)	0.125 (3)	0.375 (10)		450 (31)	396 (27)	11 / 5
2.50 (64)	x 14 (356)	2.50 (65)	0.125 (3)	0.375 (10)		345 (24)	303 (21)	13 / 6
3.00 (76)	x 14 (356)	3.00 (76)	0.125 (3)	0.375 (10)		289 (20)	254 (17)	15 / 7
4.00 (101)	x 16 (406)	4.00 (102)	0.125 (3)	0.375 (10)		300 (21)	264 (18)	18 / 8
5.00 (127)	x 17 (432)	5.00 (127)	0.125 (3)	0.375 (10)		220 (16)	193 (13)	25 / 11
6.00 (152)	x 18 (457)	6.00 (152)	0.125 (3)	0.375 (10)		200 (14)	176 (12)	28 / 13
8.00 (203)	x 20 (508)	8.00 (203)	0.125 (3)	0.375 (10)		190 (13)	167 (12)	50 / 23
10.0 (254)	x 24 (610)	10.0 (254)	0.125 (3)	0.375 (10)		165 (11)	132 (9)	70 / 32
12.0 (305)	x 25 (635)	12.0 (305)	0.125 (3)	0.375 (10)		125 (9)	110 (8)	90 / 41

# Flange Drilling for Models FTC, FC, KWA\*, KMC\*, and BFMC-FFF

Connector Size		Bolt Circle		Number of Holes	Models FTC, FC, KWA*, BFMC-FFF Hole Size		KMC Tap Size
In.	(mm)	In.	(mm)		In.	(mm)	
1	(25)	3-1/8	(79)	4	5/16	(16)	1/2 - 13 UNC
1-1/4	(32)	3-1/2	(89)	4	5/16	(16)	1/2 - 13 UNC
1-1/2	(38)	3-7/8	(98)	4	5/16	(16)	5/8 - 11 UNC
2	(50)	4-3/4	(121)	4	3/4	(19)	5/8 - 11 UNC
2-1/2	(63)	5-1/2	(140)	4	3/4	(19)	5/8 - 11 UNC
3	(75)	6	(152)	4	3/4	(19)	5/8 - 11 UNC
3-1/2	(89)	7	(178)	8	3/4	(19)	5/8 - 11 UNC
4	(100)	7-1/2	(191)	8	3/4	(19)	5/8 - 11 UNC
5	(127)	8-1/2	(216)	8	7/8	(22)	3/4 - 10 UNC
6	(152)	9-1/2	(241)	8	7/8	(22)	3/4 - 10 UNC
8	(203)	11-3/4	(298)	8	7/8	(22)	3/4 - 10 UNC
10	(254)	14-1/4	(362)	12	1	(25)	7/8 - 9 UNC
12	(305)	17	(432)	12	1	(25)	7/8 - 9 UNC
14	(356)	18-3/4	(476)	12	1-1/8	(29)	-
16	(406)	21-1/4	(540)	16	1-1/8	(29)	-
18	(457)	22-3/4	(578)	16	1-1/4	(32)	-
20	(508)	25	(635)	20	1-1/4	(32)	-
22	(559)	27-1/4	(692)	20	1-3/8	(35)	-
24	(610)	29-1/2	(749)	20	1-3/8	(35)	-
26	(660)	31-3/4	(806)	24	1-3/8	(35)	-
28	(711)	34	(864)	28	1-3/8	(35)	-
30	(762)	36	(914)	28	1-3/8	(35)	-
36	(914)	42-3/4	(1086)	32	1-5/8	(41)	-

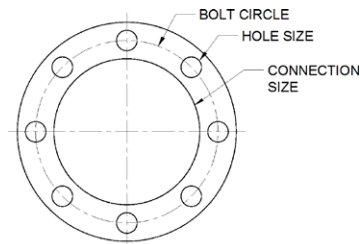

Bolting patterns per ANSI standards

## Specifications

Flexible pipe connectors shall be used on all piping connected to rotating equipment to reduce the transmission of noise and vibration, and to eliminate stresses in piping systems due to misalignment and thermal movement of the piping.

Neoprene based flexible connectors shall be of the single- or double-sphere molded joint configuration and shall meet or exceed specifications of the Rubber Expansion Joint Division, Fluid Sealing Association.

Model FC, FTC, KWA\* and KMA\* connectors shall be made of molded EPDM reinforced with nylon tire cord and shall have mild steel floating flanges or female union ends.

Model BFMC and V-Loop connectors shall be made of (stainless steel) (bronze) flexible bellows with (stainless steel) (bronze) braided outer cover and shall have (flanged) (threaded) (grooved) carbon steel end fittings.

Control rods shall be used with unanchored systems or with spring-mounted equipment where the pressures and movements exceed those the connectors are designed to withstand.

Flexible connectors shall be KINFLEX types FTC, FC, KWA\*, KMA\*, BFMC, or V-Loop as provided by Kinetics Noise Control, Inc.

*\*Not shown. See [kineticsnoise.com/kinflex](http://kineticsnoise.com/kinflex) for details.*



kineticsnoise.com  
sales@kineticsnoise.com  
1-800-959-1229