

# KINETICS®

## Isolation Hangers

### Model RH

#### Description

Kinetics Model RH Vibration Isolation Hangers are designed to reduce the transmission of vibration and noise produced by suspended equipment, piping, and ductwork. RH Hangers incorporate a color-coded elastomer-in-shear insert with a load plate, assembled into a stamped or welded hanger bracket. Model RH hangers are a unique utilization of elastomer, loading the material in shear rather than compression, increasing allowable strain without accelerating deterioration. RH Hangers will allow support rod misalignment through a 30° arc. Isolation brackets will carry a 500% overload without failure. Hangers are available in deflections from 0.20" to 0.57" (5 mm to 15 mm) and in capacities up to 2,000 lbs (907 kg). RH Hangers may be selected where first cost must be minimized. Kinetics Model RH Hangers are recommended for the isolation of vibration produced by suspended mechanical equipment, in-line and exhaust fans, ductwork, piping, etc.



#### Application

Kinetics Model RH hangers are used to isolate suspended sources of audible frequency vibration, or isolation of noise in piping and ductwork systems. Model RH hangers are shipped fully assembled and ready for installation in threaded rod suspension systems. Model RH hangers are available in a wide range of load selections and up to 0.57" (15 mm) static deflection and can be provided with laborsaving accessories for adaption to wire or strap suspension systems.

#### Features

- Elastomer-in-shear noise isolator
- Static deflections up to 0.57" (15 mm)
- Load capacities up to 2000 lbs. (907 kg)
- Insert color coded for load capacity
- 500% overload fail-safe steel bracket
- 30° allowable rod misalignment bracket design

Hanger Type	Standard Ratings				Spring Color	Dimensions									
	Load		Deflection			L		W		A		Dmax		H	
	lbs	kg	in	mm		in	mm	in	mm	in	mm	in	mm	in	mm
RH-75A	75	34	0.09	2	Black	2.72	69	2.15	55	1.50	38	0.38	10	0.45	11
RH-125A	125	57	0.04	1	Black	2.72	69	2.15	55	1.50	38	0.38	10	0.45	11
RH-125B	125	57	0.35	9	Black	5.91	150	3.15	80	2.25	57	0.75	19	1.60	41
RH-175B	175	79	0.35	9	Red	5.91	150	3.15	80	2.25	57	0.75	19	1.60	41
RH-300B	300	136	0.53	13	Green	5.91	150	3.15	80	2.25	57	0.75	19	1.60	41
RH-450B	450	204	0.55	14	White	5.91	150	3.15	80	2.25	57	0.75	19	1.60	41
RH-550D	550	249	0.40	10	White	5.91	150	3.15	80	2.25	57	0.63	16	1.84	47
RH-700C	700	318	0.57	14	Purple	8.59	218	5.58	142	3.63	92	0.88	22	2.00	51
RH-1100C	1100	499	0.46	12	Yellow	8.59	218	5.58	142	3.63	92	0.88	22	2.00	51
RH-2000C	2000	907	0.53	13	Pink	8.59	218	5.58	142	3.63	92	0.88	22	2.00	51

## Specifications

Vibration isolators with maximum static deflection requirements under operating load conditions not exceeding 0.57" (15 mm) shall be hangers consisting of an elastomer-in-shear insert encased in a welded steel bracket and provided with a stamped load transfer cap.

The elastomer insert shall be molded from oil resistant compounds, shall be color coded to indicate load capacity and selected to operate within its published load range.

The hanger bracket shall be designed to carry a 500% overload without failure and to allow support rod misalignment through a 30° arc without metal-to-metal contact or other short circuit.

Isolation hangers shall be selected by the manufacturer for each specific application to comply with deflection requirements as shown on the Vibration Isolation Schedule or as indicated on the project documents.

Vibration isolation hanger assembly shall be Model RH, as manufactured by Kinetics Noise Control, Inc.

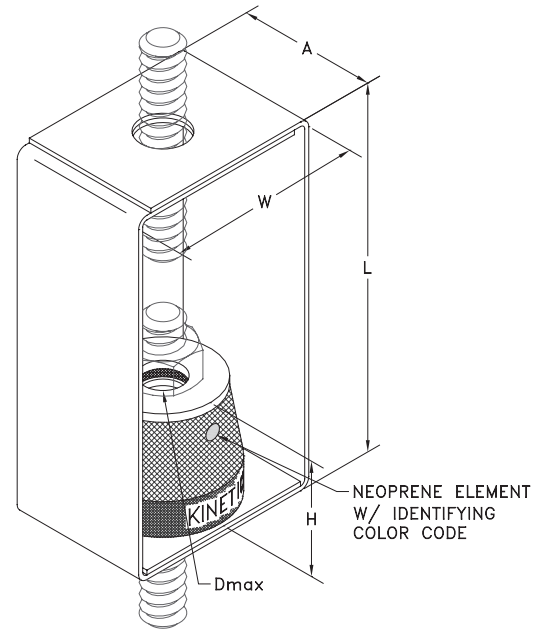

kineticsnoise.com  
sales@kineticsnoise.com  
1-800-959-1229