

# KINETICS®

## 1" and 2" Deflection Isolation Hangers Model SFH

### Description

Kinetics Model SFH Vibration Isolation Hangers consist of free-standing, large diameter, laterally stable steel springs in series with a precompressed molded fiberglass insert assembled into a stamped or welded hanger bracket. To assure stability, the spring element has a minimum lateral spring stiffness of 1.0 times the rated vertical stiffness. Hangers will allow support rod misalignment through a 30° arc without short circuiting. Isolation brackets will carry a 500% overload without failure. Model SFH hangers are superior to hangers which incorporate a spring only, that can transmit noise through the all-metal construction, and hangers incorporating noise stop pads only, that can transmit low frequency vibration which a spring would isolate. Hangers are available in deflections 1.04" to 2.20" (26 to 56 mm), and in capacities from 35 to 3500 lbs. (16 to 1588 kg). Kinetics Model SFH combination hangers are recommended for the isolation of vibration produced by suspended mechanical equipment, low speed suspended fans, transformers, ductwork, piping, etc.

### Application

Kinetics Model SFH hangers are recommended for use near critically quiet areas for isolating any suspended source of both audible and inaudible noise and vibration. Suspended mechanical equipment such as in-line fans, cabinets fans, and piping and ductwork in close proximity to mechanical equipment are typical uses of Model SFH hangers.

High sound transmission loss ceiling systems can be effectively isolated by the use of Model SFH hangers in the ceiling suspension system. This hanger model is particularly suitable for use in isolated ceiling systems used to shield spaces from mechanical equipment rooms, flyover aircraft, and similar sound isolation involving predominantly low frequency noise.

Standard Model SFH hangers are shipped fully assembled and ready for installation in threaded rod suspension systems.

Model SFH hangers are available in a wide range of load and static deflection selections and can be provided with labor-saving accessories for adaption to wire or strap suspension systems, and spring may be preloaded for ease in erecting piping at a fixed elevation.



- Polyester Powder Coated Bracket and Spring Coil
- Self-Centering Cap Patent No. 5,653,426

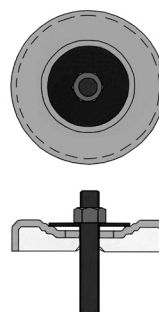

### How the self centering no short cap works:

Indexed steps in spring cap correspond to standard washer diameters for the appropriate rod diameter. The washer and rod stay centered in the cap.

## Specifications

Vibration isolators for suspended equipment with minimum static deflection requirement exceeding 0.4" (10 mm), and where both high and low frequency vibration is to be isolated, shall be hangers consisting of a laterally stable steel spring in series with a pre-compressed molded fiberglass insert, complete with a load plate and assembled in a stamped or welded steel bracket.

The fiberglass insert shall be individually coated with a flexible, moisture-impervious elastomeric membrane. The insert shall be molded from glass fibers with fiber diameters not exceeding 0.00027" (6.8 microns) and with a modulus of elasticity of 10.5 million PSI (738,223 kg/cm<sup>2</sup>).

Natural frequency of fiberglass vibration isolators shall be essentially constant for the operating load range of the supported equipment.

The spring element shall have a minimum lateral stiffness of 1.0 times the rated vertical stiffness.

Vibration isolators shall be color coded or otherwise identified to indicate load capacity.

The hanger bracket shall be designed to carry a 500% overload without failure and to allow support rod misalignment through a 30° arc without metal-to-metal contact or other short circuit.

The hanger bracket shall incorporate spring caps with indexed steps which correspond to the washer diameter of appropriately sized hanger rod to keep the rod centered in the spring cap and reduce rod misalignment. The spring caps are protected under U.S. patent number 5,653,426.

Isolation hangers shall be selected by the manufacturer for each specific application to comply with deflection requirements as shown on the

Vibration Isolation Schedule or as indicated on the project documents.

The combination isolation hanger assembly with fiberglass insert shall be Model SFH, as manufactured by Kinetics Noise Control, Inc.

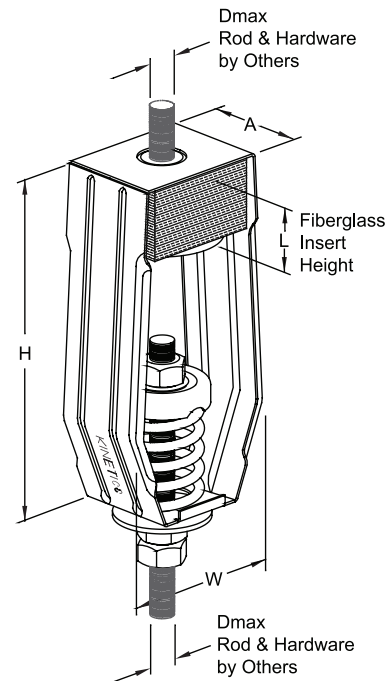

Hanger Type	Spring Color	Standard Ratings						Dimensions									
		Spring O.D.		Load		Deflection		L		H		W		A		Dmax	
		in	mm	lbs	kg	in	mm	in	mm	in	mm	in	mm	in	mm	in	mm
SFH-1-35	Blue	1.75	44	35	16	1.72	44	1.13	29	7.38	187	3.69	94	2.25	57	0.63	16
SFH-1-70	Green	1.75	44	70	32	1.63	41	1.13	29	7.38	187	3.69	94	2.25	57	0.63	16
SFH-1-125	Gray	1.75	44	125	57	1.57	40	1.13	29	7.38	187	3.69	94	2.25	57	0.63	16
SFH-1-245	Brown	1.75	44	245	111	1.46	37	1.13	29	7.38	187	3.69	94	2.25	57	0.63	16
SFH-1-370	Orange	1.75	44	370	168	1.12	28	1.13	29	7.38	187	3.69	94	2.25	57	0.63	16
SFH-1-500	Beige	1.75	44	500	227	1.07	27	1.25	32	7.38	187	3.69	94	2.25	57	0.63	16
SFH-1-600	Chrome	1.75	44	600	272	1.08	27	1.25	32	7.38	187	3.69	94	2.25	57	0.63	16
SFH-1-700	Beige/Wht	1.75	44	700	318	1.08	28	1.25	32	7.38	187	3.69	94	2.25	57	0.63	16
SFH-1-805	Chrm/Wht	1.75	44	805	365	1.10	28	1.25	32	7.38	187	3.69	94	2.25	57	0.63	16
SFH-1-50	Beige	3.00	76	50	23	1.00	25	1.50	38	8.59	218	5.58	142	3.63	92	1.00	25
SFH-1-100	Chrome	3.00	76	100	45	1.00	25	1.50	38	8.59	218	5.58	142	3.63	92	1.00	25
SFH-1-250	Blue	3.00	76	250	113	1.90	48	1.50	38	8.59	218	5.58	142	3.63	92	1.00	25
SFH-1-450	Green	3.00	76	450	204	1.69	43	1.50	38	8.59	218	5.58	142	3.63	92	1.00	25
SFH-1-625	Black	3.00	76	625	283	1.61	41	1.50	38	8.59	218	5.58	142	3.63	92	1.00	25
SFH-1-800	Gray	3.00	76	800	363	1.50	38	1.50	38	8.59	218	5.58	142	3.63	92	1.00	25
SFH-1-1000	Red	3.00	76	1000	454	1.23	31	1.50	38	8.59	218	5.58	142	3.63	92	1.00	25
SFH-1-1250	Brown	3.00	76	1250	567	1.18	30	1.50	38	8.59	218	5.58	142	3.63	92	1.00	25
SFH-1-1700	Orange	3.00	76	1700	771	1.05	27	1.50	38	8.59	218	5.58	142	3.63	92	1.00	25
SFH-1-2200	Org/Gray	3.00	76	2200	998	1.05	27	1.50	38	9.50	241	5.00	127	4.75	121	1.00	25
SFH-1-2465	Blue	3.00	76	2465	1118	1.05	27	1.50	38	9.50	241	5.00	127	4.75	121	1.00	25
SFH-1-2865	Blue/Gry	3.00	76	2865	1300	1.05	27	1.50	38	9.50	241	5.00	127	4.75	121	1.00	25
SFH-1-3500	Blue/Brn	3.00	76	3500	1588	1.06	27	1.50	38	9.50	241	5.00	127	4.75	121	1.00	25
SFH-2-35	Blue	1.75	44	35	16	2.00	51	1.13	29	7.38	187	3.69	94	2.25	57	0.63	16
SFH-2-70	Green	1.75	44	70	32	2.00	51	1.13	29	7.38	187	3.69	94	2.25	57	0.63	16
SFH-2-120	Gray	1.75	44	120	54	2.00	51	1.13	29	7.38	187	3.69	94	2.25	57	0.63	16
SFH-2-220	Brown	1.75	44	220	100	2.13	54	1.13	29	7.38	187	3.69	94	2.25	57	0.63	16
SFH-2-260	Blue	3.00	76	260	118	2.20	56	2.00	51	8.59	218	5.58	142	3.63	92	1.00	25
SFH-2-465	Green	3.00	76	465	211	2.02	51	2.00	51	8.59	218	5.58	142	3.63	92	1.00	25
SFH-2-720	Black	3.00	76	720	327	1.93	49	2.00	51	8.59	218	5.58	142	3.63	92	1.00	25
SFH-2-850	White	3.00	76	850	386	2.01	51	2.00	51	8.59	218	5.58	142	3.63	92	1.00	25
SFH-2-1025	Beige	3.00	76	1025	465	1.81	46	2.00	51	8.59	218	5.58	142	3.63	92	1.00	25
SFH-2-1200	Chrome	3.00	76	1200	544	1.77	45	2.00	51	8.59	218	5.58	142	3.63	92	1.00	25
SFH-2-2000	Orange	5.00	127	2000	909	-	-	1.25	32	12.00	305	6.00	152	6.00	152	1.00	25
SFH-2-2500	Blue	5.00	127	2500	1136	-	-	1.25	32	12.00	305	6.00	152	6.00	152	1.00	25
SFH-2-2750	Blu/Blu	5.00	127	2750	1250	-	-	1.25	32	12.00	305	6.00	152	6.00	152	1.00	25
SFH-2-3025	Blu/Grn	5.00	127	3025	1375	-	-	1.25	32	12.00	305	6.00	152	6.00	152	1.00	25
SFH-2-3250	Blu/Blk	5.00	127	3250	1477	-	-	1.25	32	12.00	305	6.00	152	6.00	152	1.00	25



[kineticsnoise.com](http://kineticsnoise.com)  
[sales@kineticsnoise.com](mailto:sales@kineticsnoise.com)  
1-800-959-1229

# KINETICS®

## 4" Deflection Isolation Hangers Model SFH

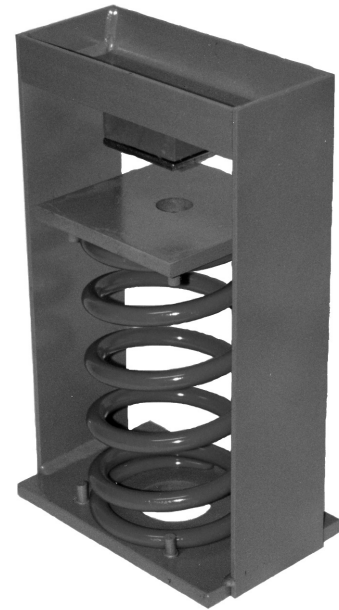

### Application

Kinetics SFH hangers are recommended for use near critically quiet areas for isolating any suspended source of both audible and inaudible noise and vibration. Suspended mechanical equipment such as in-line fans, cabinet fans, and piping and ductwork in close proximity to mechanical equipment are typical uses of Model SFH hangers.

Kinetics' minimum recommendation for the placement of spring hangers is that they be installed on all piping in the equipment room and on the first 50' (15 m) for piping that extends outside of the equipment room. For typical installations, the three spring hangers closest to the equipment should have equal deflection to the equipment isolators. The remaining spring hangers should have a minimum deflection of 1" (25 mm). In noise sensitive areas, the pipe hangers selected should have the same deflection as that specified for the equipment isolation and all piping in the building should be isolated.

Standard Model SFH hangers are shipped fully assembled and ready for installation in threaded rod suspension systems.

Model SFH hangers are available in a wide range of load and static deflection selections and can be provided with labor-saving accessories for adaption to wire or strap suspension systems, and spring may be preloaded for ease in erecting piping at a fixed elevation.

### Description

Kinetics Model SFH Vibration Isolation Hangers consist of free-standing, large diameter, laterally stable steel springs in series with a precompressed molded fiberglass insert assembled into a stamped or welded hanger bracket. Hangers incorporate a high deflection, color-coded spring element and a fiberglass isolator complete with load plate. To assure stability, the spring element has a minimum lateral spring stiffness of 1.0 times the rated vertical stiffness. Springs are polyester powder coated, with a 1000 hour salt spray rating per ASTM B-117. Hangers will allow support rod misalignment through a 30° arc without short circuiting. Isolation brackets will carry a 500% overload without failure. Model SFH hangers are superior to hangers which incorporate a spring only, which can transmit noise through the all-metal construction, and hangers incorporating noise stop pads only, that can transmit low frequency vibration. Hangers are available in deflections 4.05" to 4.75" (104 to 112 mm) and in capacities from 100 to 3850 lbs. (46 to 1747 kg). Kinetics Model SFH combination hangers are recommended for the isolation of vibration produced by suspended mechanical equipment, low speed suspended fans, transformers, ductwork, piping, etc.

Hanger Type	Spring Color	Spring O.D.		Rated Load		L		H		W		A		B		Dmax	
		in	mm	lbs	kg	in	mm	in	mm	in	mm	in	mm	in	mm	in	mm
SFH-4-100	Gray	5.63	143	100	45	2.66	68	16.00	406	9.38	238	4.00	102	6.00	152	1.13	29
SFH-4-250	Blue	5.63	143	250	114	2.66	68	16.00	406	9.38	238	4.00	102	6.00	152	1.13	29
SFH-4-500	Green	5.63	143	500	227	2.66	68	16.00	406	9.38	238	4.00	102	6.00	152	1.13	29
SFH-4-750	Black	5.63	143	750	341	2.66	68	16.00	406	9.38	238	4.00	102	6.00	152	1.13	29
SFH-4-1000	Red	5.63	143	1000	454	2.66	68	16.00	406	9.38	238	4.00	102	6.00	152	1.13	29
SFH-4-1250	Brown	5.63	143	1250	568	2.66	68	16.00	406	9.38	238	4.00	102	6.00	152	1.13	29
SFH-4-1600	Orange	5.63	143	1600	726	2.66	68	16.00	406	9.38	238	4.00	102	6.00	152	1.13	29
SFH-4-2250	Beige	8.00	203	2250	1023	3.17	81	18.50	470	13.50	343	6.00	152	8.00	203	1.13	29
SFH-4-2500	Bge/Blu	8.00	203	2500	1135	3.17	81	18.50	470	13.50	343	6.00	152	8.00	203	1.13	29
SFH-4-2750	Bge/Grn	8.00	203	2750	1249	3.17	81	18.50	470	13.50	343	6.00	152	8.00	203	1.13	29
SFH-4-3000	Bge/Blk	8.00	203	3000	1362	3.17	81	18.50	470	13.50	343	6.00	152	8.00	203	1.13	29
SFH-4-3250	Bge/Red	8.00	203	3250	1476	3.17	81	18.50	470	13.50	343	6.00	152	8.00	203	1.13	29
SFH-4-3500	Bge/Brn	8.00	203	3500	1589	3.17	81	18.50	470	13.50	343	6.00	152	8.00	203	1.13	29
SFH-4-3850	Bge/org	8.00	203	3850	1748	3.17	81	18.50	470	13.50	343	6.00	152	8.00	203	1.13	29

## Specifications

Vibration isolators for suspended equipment with minimum static deflection requirement exceeding 0.4" (10 mm), and where both high and low frequency vibration is to be isolated, shall be hangers consisting of a laterally stable steel spring in series with a precompressed molded fiberglass insert complete with load plate and assembled in a stamped or welded steel bracket.

The bracket shall be finished with an polyester powder coating. The manufacturer shall provide independent laboratory testing showing that the bracket with this finish has endured a minimum of 1,000 hours of exposure to salt spray fog testing per ASTM B117 without signs of corrosion.

The fiberglass insert shall be individually coated with a flexible, moisture impervious elastomeric membrane. The insert shall be molded from glass fibers with fiber diameters not exceeding 0.00027" (6.8 microns) and with a modulus of elasticity of 10.5 million PSI (738,223 kg/sq. cm).

Natural frequency of fiberglass vibration isolators shall be essentially constant for the operating load range of the supported equipment.

The spring element shall have a minimum lateral stiffness of 1.0 times the rated vertical stiffness.

Vibration isolators shall be color coded or otherwise identified to indicate load capacity.

The hanger bracket shall be designed to carry a 500% overload without failure and to allow support rod misalignment through a 30° arc without metal-to-metal contact or other short circuit.

Isolation hangers shall be selected by the manufacturer for each specific application to comply with deflection requirements as shown on the Vibration Isolation Schedule or as indicated on the project documents.

The combination isolation hanger assembly with fiberglass insert shall be Model SFH, as manufactured by Kinetics Noise Control, Inc.

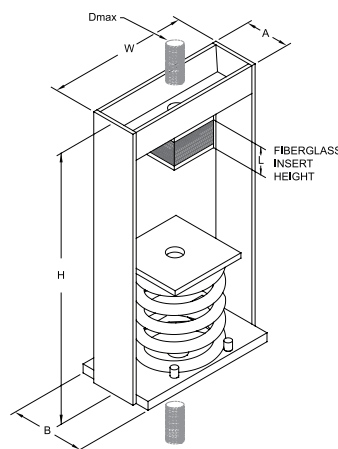

kineticsnoise.com  
sales@kineticsnoise.com  
1-800-959-1229