

## MODEL FDS INSTALLATION INSTRUCTIONS

- 1) THREAD THE LEVELING BOLT INTO THE TOP LOAD PLATE OF THE SPRING UNTIL THE HEAD OF THE BOLT IS WITHIN  $\frac{1}{8}$ " OF THE TOP LOAD PLATE OF THE SPRING.
- 2) LOCATE EACH ISOLATOR IN TO POSITION BASED ON SUBMITTAL DRAWING USING COLOR CODED SPRINGS AS IDENTIFICATION.
- 3) REMOVE THE SMALL CAP SCREW AND WASHER. RAISE THE EQUIPMENT BASE WITH JACKS OR SIMILAR TOOLS (DO NOT ATTEMPT TO RAISE THE BASE VIA ONE (1) LIFTING POINT, BUT LIFT EVENLY AROUND THE EQUIPMENT. SLIDE THE SPRING ISOLATOR UNDER THE EQUIPMENT OR MOUNTING BRACKET WITH THE BOLT HEAD ON THE UNDERSIDE OF THE BRACKET.
- 4) INSERT THE SMALL CAP SCREW THROUGH THE BRACKET AND THREAD INTO THE TOP OF THE LEVELING BOLT AND TIGHTEN FINGER TIGHT.
- 5) IF THE EQUIPMENT WEIGHS 1,000 LBS OR MORE, THE PLACEMENT OF BLOCKS BENEATH THE EQUIPMENT NEAR EACH ISOLATOR POINT WILL ASSIST INSTALLATION. THE HEIGHT OF EACH BLOCK SHOULD BE SUCH THAT THE EQUIPMENT WILL BE AT ITS REQUIRED OPERATING HEIGHT WHEN SITTING ON THE BLOCKS.
- 6) LOWER THE EQUIPMENT (EVENLY) ONTO THE SPRING ISOLATORS OR BLOCKS, TAKING CARE NOT TO OVERLOAD ANY ONE ISOLATOR AND TAKING CARE NOT TO PUSH THE EQUIPMENT SIDWAYS. BEFORE ADJUSTING THE ISOLATORS, IT IS NECESSARY THAT THE EQUIPMENT BE BROUGHT UP TO ITS OPERATING WEIGHT.
- 7) FOR SMALL EQUIPMENT, WHERE BLOCKS ARE NOT USED, TURN THE LEVELING BOLT COUNTER-CLOCKWISE ON THE LOWEST EQUIPMENT CORNER UNTIL THE EQUIPMENT IS LEVEL. DO NOT ATTEMPT TO PLACE ALL THE WEIGHT ON ONE SPRING, BUT DISTRIBUTE THE LOAD PROPORTIONATELY BY ADJUSTING EACH ISOLATOR IN SEQUENCE.

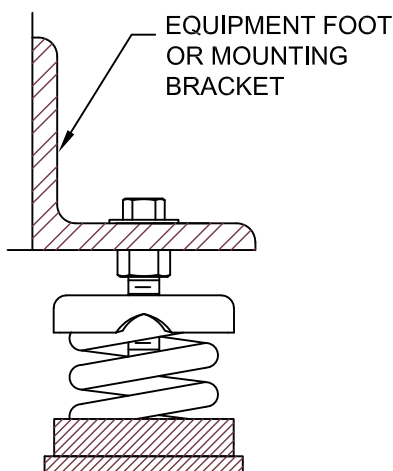
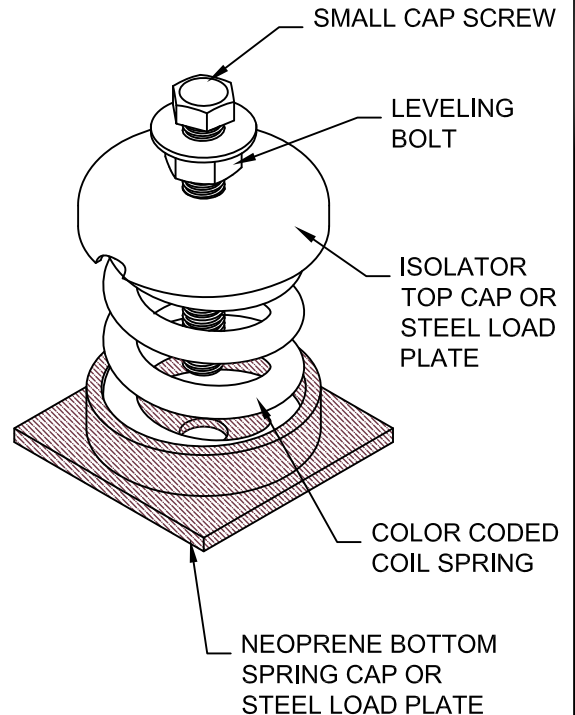

- 8) FOR LARGER EQUIPMENT, WHERE BLOCKS ARE USED, TURN THE LEVELING BOLT COUNTER-CLOCKWISE ONE OR TWO TURNS AT EACH ISOLATOR. DISCONTINUE TURNING AT ANY LOCATION WHERE BLOCKING CAN BE REMOVED. CONTINUE TO ADJUST EACH LEVELING BOLT (IN SEQUENCE) UNTIL THE EQUIPMENT IS AT ITS OPERATING HEIGHT, SHOWN IN THE APPROPRIATE SUBMITTAL DRAWING.
- 9) THE BLOCKS MAY BE REMOVED. IT MAY BE DESIRED TO LEAVE THE EQUIPMENT ON BLOCKS UNTIL IT IS OPERATING, THUS ELIMINATING FUTURE RELEVELING SHOULD THERE BE A MAJOR WEIGHT SHIFT DURING START UP.
- 10) TIGHTEN THE SMALL CAP SCREW, THUS SECURING THE SPRING ISOLATOR TO THE SUPPORTED EQUIPMENT AND LOCKING THE LEVELING BOLT AGAINST TURNING.
- 11) DO NOT ATTEMPT TO MOVE THE EQUIPMENT Laterally While It Is Supported On The Isolators. IF IT IS NECESSARY TO MOVE THE EQUIPMENT, REMOVE THE WEIGHT FROM THE ISOLATORS BY RAISING THE EQUIPMENT BEFORE MOVING. FAILURE TO FOLLOW THIS PROCEDURE COULD RESULT IN BENT OR BROKEN LEVELING BOLTS OR SPRINGS, OR DAMAGE TO THE NEOPRENE BOTTOM SPRING CAP.

NOTE: FDS ISOLATORS ARE NOT SEISMICALLY RATED AND CANNOT BE COUNTED ON TO PROVIDE RESTRAINT IN SEISMIC OR WIND APPLICATIONS.

# MODEL FDS INSTALLATION INSTRUCTIONS (TYPE II)

- 1) PLACE EQUIPMENT TO BE ISOLATED ON TEMPORARY BLOCKING AND SHIM UNTIL EQUIPMENT IS LEVEL.
- 2) LOCATE EACH ISOLATOR IN TO POSITION BASED ON SUBMITTAL DRAWING USING COLOR CODED SPRINGS AS IDENTIFICATION.
- 3) REMOVE LEVELING HARDWARE FROM THE ISOLATOR AND SLIDE ISOLATOR INTO PROPER POSITION.
- 4) INSERT LEVELING BOLT, WITH WASHER THROUGH THE HOLE IN THE MOUNTING BRACKET (A). THEN PLACE A WASHER, TWO NUTS AND A SECOND WASHER ON BOLT (B). AS THE NUTS ARE THREADED ONTO THE BOLT, ALLOW THE BOLT TO GO INTO THE UNTHREADED HOLE IN THE TOP PLATE (C). CONTINUE THREADING UNTIL BOLT HEAD CONTACTS THE TOP OF THE EQUIPMENT BRACKET.

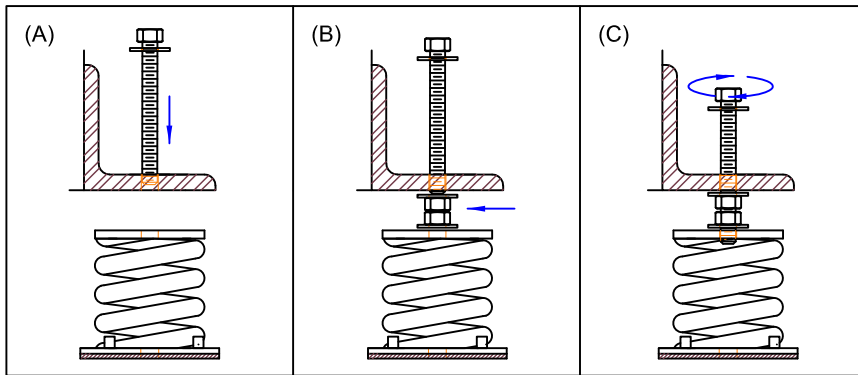
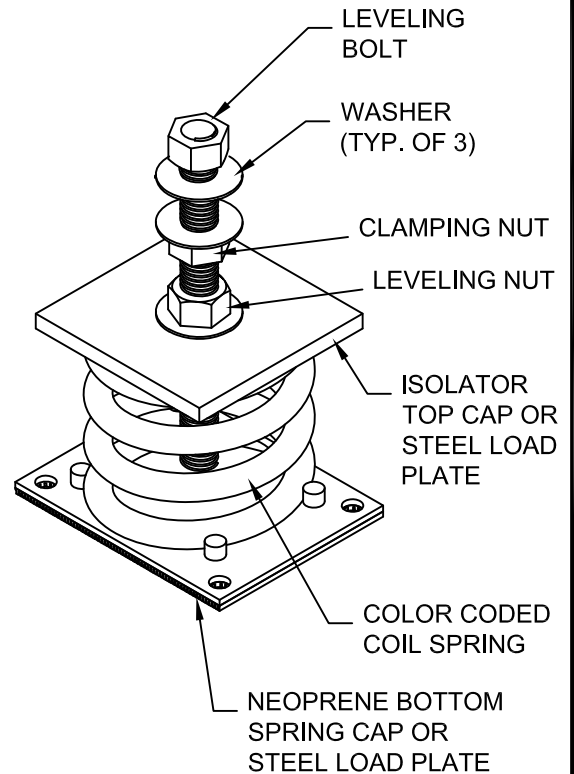

- 5) TIGHTEN TOP NUT TO THE BOTTOM OF THE EQUIPMENT BRACKET. THIS WILL PREVENT THE BOLT FROM TURNING AS THE LEVELING ADJUSTMENTS ARE MADE. THIS SHOULD BE DONE FOR ALL ISOLATORS BEFORE ATTEMPTING THE ADJUSTMENTS. BEFORE ADJUSTING THE ISOLATORS, IT IS NECESSARY THAT THE EQUIPMENT BE BROUGHT UP TO ITS OPERATING WEIGHT.

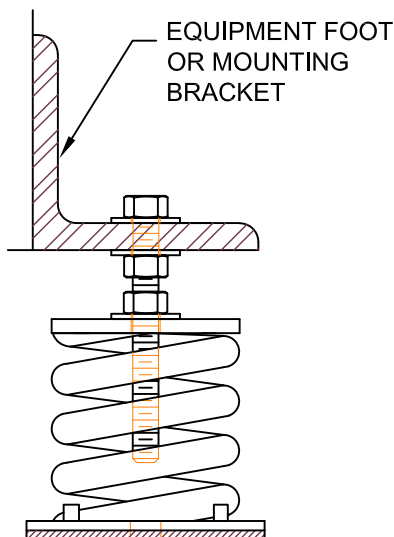

- 6) TURN THE LOWER NUT IN A CLOCKWISE DIRECTION ONE TO TWO TURNS AT EACH ISOLATOR. CONTINUE DOING THIS UNTIL THE BLOCKING CAN BE REMOVED. DISCONTINUE TURNING AT ANY LOCATION WHERE BLOCKING CAN BE REMOVED, BUT CONTINUE ADJUSTING AT OTHER LOCATIONS UNTIL ALL BLOCKING CAN BE REMOVED. EQUIPMENT SHOULD BE APPROXIMATELY LEVEL WHEN THIS IS DONE.
- 7) REMOVE ALL BLOCKING FROM UNDER EQUIPMENT AND VERIFY THAT NO DEBRIS IS LEFT BENEATH THE EQUIPMENT. EQUIPMENT SHOULD BE PROPERLY ISOLATED BY THE SPRING ISOLATORS AT THIS TIME.
- 8) DO NOT ATTEMPT TO MOVE THE EQUIPMENT Laterally While It Is Supported on the Isolators. IF IT IS NECESSARY TO MOVE THE EQUIPMENT, REMOVE THE WEIGHT FROM THE ISOLATORS BY RAISING THE EQUIPMENT BEFORE MOVING. FAILURE TO FOLLOW THIS PROCEDURE COULD RESULT IN DAMAGE TO THE ISOLATORS, EQUIPMENT OR PERSONNEL.

NOTE: FDS ISOLATORS ARE NOT SEISMICALLY RATED AND CANNOT BE COUNTED ON TO PROVIDE RESTRAINT IN SEISMIC OR WIND APPLICATIONS.