

ICC 1" DEFLECTION ISOLATION HANGERS
IP UNITS (INCHES AND POUNDS) SI UNITS [MM AND KG]

TYPE	A	D	H	J	K	W
12/210	2.25 [57.2]	0.38 [9.6]	7.38 [187.5]	1.56 [39.6]	0.66 [16.8]	3.69 [93.7]

STANDARD RATINGS				SPRING COIL			INSERT COLOR
TYPE	SIZE	LOAD	DEFL.	COLOR	FREE HT.	O.D.	
ICC	1-12	12 [5]	1.00 [25]	SILVER	3.19 [81]	1.75 [44]	BLACK
ICC	1-18	18 [8]	1.00 [25]	YELLOW	3.19 [81]	1.75 [44]	BLACK
ICC	1-24	24 [11]	1.00 [25]	BLUE	3.19 [81]	1.75 [44]	BLACK
ICC	1-30	30 [14]	1.00 [25]	PINK	3.19 [81]	1.75 [44]	BLACK
ICC	1-37	37 [17]	1.00 [25]	WHITE	3.19 [81]	1.75 [44]	BLACK
ICC	1-50	50 [23]	1.00 [25]	GREEN	3.19 [81]	1.75 [44]	BLACK
ICC	1-75	75 [34]	1.00 [25]	BLACK	3.19 [81]	1.75 [44]	BLACK
ICC	1-100	100 [45]	1.00 [25]	GRAY	3.19 [81]	1.75 [44]	BLACK
ICC	1-150	150 [65]	1.00 [25]	RED	3.19 [81]	1.75 [44]	RED
ICC	1-210	210 [95]	1.00 [25]	BROWN	3.19 [81]	1.75 [44]	GREEN

SPECIFICATIONS:

- FOR USE WITH 3/8 IN. (10) CONCRETE ANCHORS.
- SPRING ELEMENTS AND BRACKETS ARE POWDER COATED.
- LOAD PLATES AND HARDWARE ARE BRIGHT ZINC PLATED.
- ISOLATION HANGERS HAVE A TYPICAL OVERLOAD OF 50%.
- SPRING CAPACITIES HAVE A MINIMUM K_x/K_y RATIO OF 1.0.
- SPRING ELEMENTS ARE SAFE AT SOLID LOADING.
- HANGER BRACKETS WILL CARRY AT LEAST (5) TIMES OVERLOAD WITHOUT FAILURE.
- HANGER BRACKETS WILL ALLOW 30° ROD MISALIGNMENT WITHOUT SHORT CIRCUITING.
- CHANNEL CLIP ASSEMBLY SHIPS LOOSE.

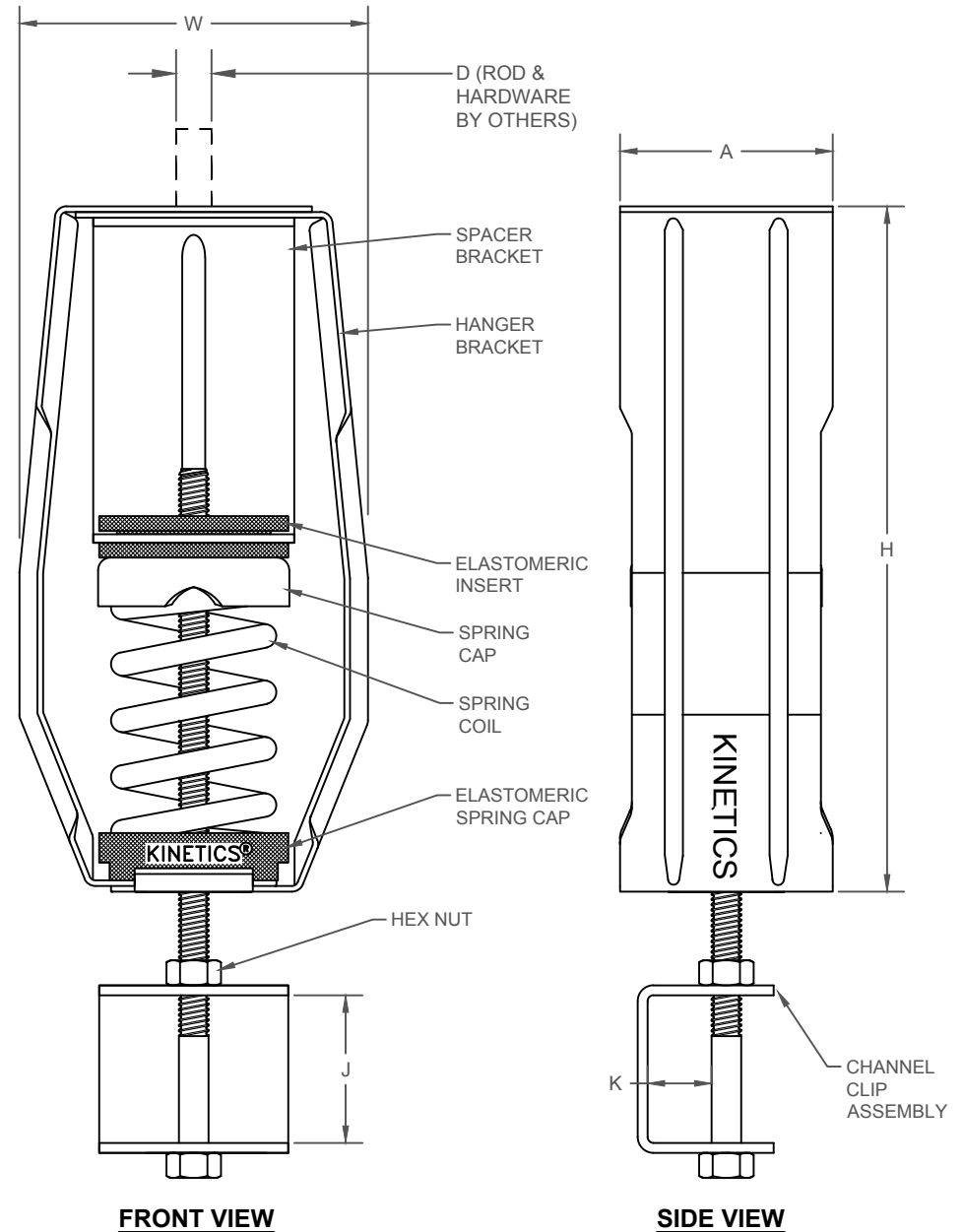

SCALE: 6" = 1' - 0"



ICC CONCRETE DECK CEILING
ISOLATION SPRING HANGER

Revised
11/18/2019

Drawing No.
AA001978

kineticsnoise.com/icc