



KINETICS® KB803

SOUND BAFFLES

Description

KB803 Sound Baffles are used to reduce overall noise levels in industrial, recreational, and other high noise areas, and are suspended from above or from the structure near the noise source. Kinetics Sound Baffles are 2.7 pcf (43 kg/m³) fiberglass, 24"x 48" (610 mm x 1219 mm), and 1-1/2" (38 mm) thick, and are sealed in a black or white fire-retardant vinyl film cover. When tested in accordance to UL-723, the cover material exhibits a flame spread of 15, and smoke development of 105;

the fuel contribution is not determinable. The average absorption ratings for KB803 Sound Baffles are shown in the table. Actual room noise reduction can be up to 10 dBA depending on the configuration of the space and the absorption present before installing baffles. Baffles are packaged ten (10) per carton.

Baffles are available to meet USDA and FDA approved requirements using various available coverings.

Acoustical Performance

Sound Absorption per ASTM C423

KB803 24" x 48" x 1-1/2" thick baffles tested in a typical suspended layout

Frequency, (Hz)	125	250	500	1000	2000	4000	NRC
Sabins 24" x 48"	2.00	5.90	11.9	14.4	12.2	7.80	-
Absorption Coefficient	0.25	0.74	1.5	1.8	1.5	0.98	1.4

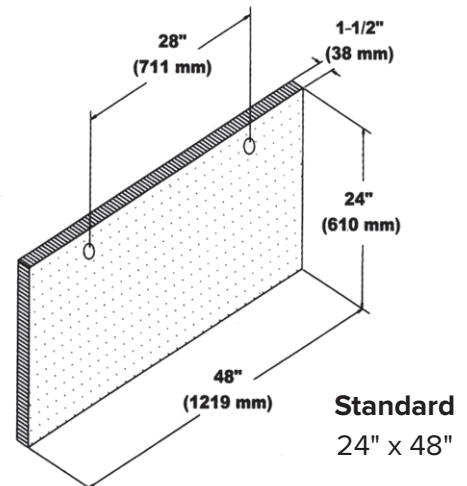

Estimating Baffles

Use the following example to estimate the number of baffles for your application.

Example:

Consider an 80' L x 40' W x 20' H walls industrial plant.

Step 1 Determine surface area:

80 x 20 x 2 (walls) = 3200

40 x 20 x 2 (walls) = 1600

80 x 40 x 1 (ceiling) = 3200

80 x 40 x 1 (floor) = 3200

Total Surface = 11200 sq. ft

Step 2 Determine the overall acoustical character of the building. Assume this building is medium hard since the floors and walls are hard, and the ceiling is medium.

Step 3 Connect 11,200 ft.² and medium hard on the nomogram. Extend the line to its intersection with the vertical reference line.

Step 4 If an 8 dB noise reduction is desired, connect a line between 8 on the "Reduction" scale, and the intersection point on the "Reference Line".

Step 5 Read 200 as the number of baffles required on the "Required" line.

Nomogram

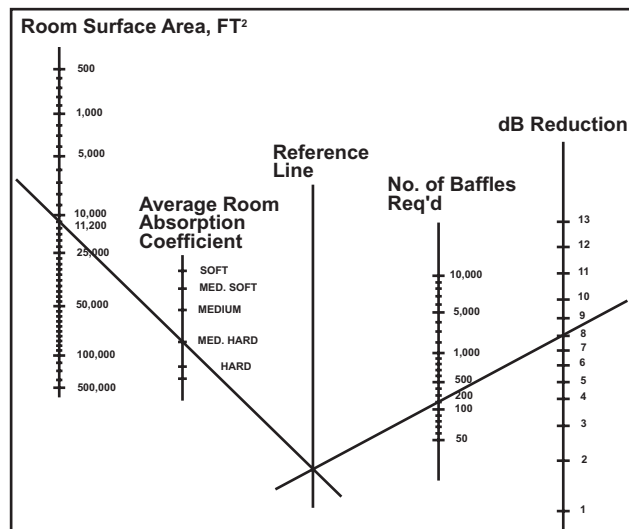

Room/Building Acoustical Characteristics

Terminology	Description
Hard	All (6) Surfaces Brick, Concrete, Marble, Tile, Steel
Medium Hard	(5) Surfaces Hard, (1) Surface Absorptive -- Carpet, Acoustical Tile, Drapes, or Open to the Outside.
Medium	(4) Surfaces Hard, (2) Surfaces Absorptive
Medium Soft	(3) Surfaces Hard, (3) Surfaces Absorptive
Soft	

Specifications

Sound baffles shall be constructed from 2.7 pcf (43 kg/m³) fiberglass, sized 24" x 48" (610 mm x 1219 mm) x 1-1/2" (38 mm) thick.

Fiberglass shall be completely wrapped and sealed with a 3 mil (76 micron) thick white vinyl film cover. The vinyl shall be heat sealed along three (3) edges which shall provide an air-tight seam. Each sound baffle shall have a quantity of two (2) brass grommets along the top edge of the baffle.

KB803 baffles used in food processing plants shall be covered with a white Tyvek[®] material which has been approved by the United States Department of Agriculture for use in food processing plants.

KB803 baffles shall have a minimum NRC Rating of 0.74 for 1-1/2" (38 mm) thickness.

The cover material of the baffles shall be Class 1 and shall exhibit a flame spread rating of 15, and a smoke development of 105 when tested in accordance with UL-723.

Sound baffles shall be model KB803 as manufactured by Kinetics Noise Control, Inc.

Installation Patterns

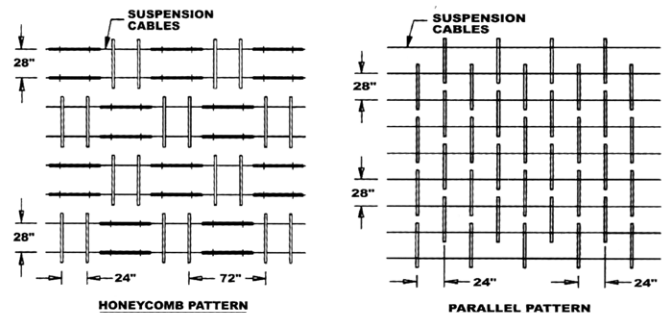

kineticsnoise.com
sales@kineticsnoise.com
1-800-959-1229