

# RH-D HANGER

IP UNITS (INCHES AND POUNDS)

TYPE	L	W	A	Dmax	H	Ød
RH-550D	5.91	3.15	2.25	0.63	1.84	0.81

## STANDARD RATINGS

TYPE	SIZE	RATED		COLOR CODE
		LOAD	DEFL.	
RH	550D	550	0.40	WHITE

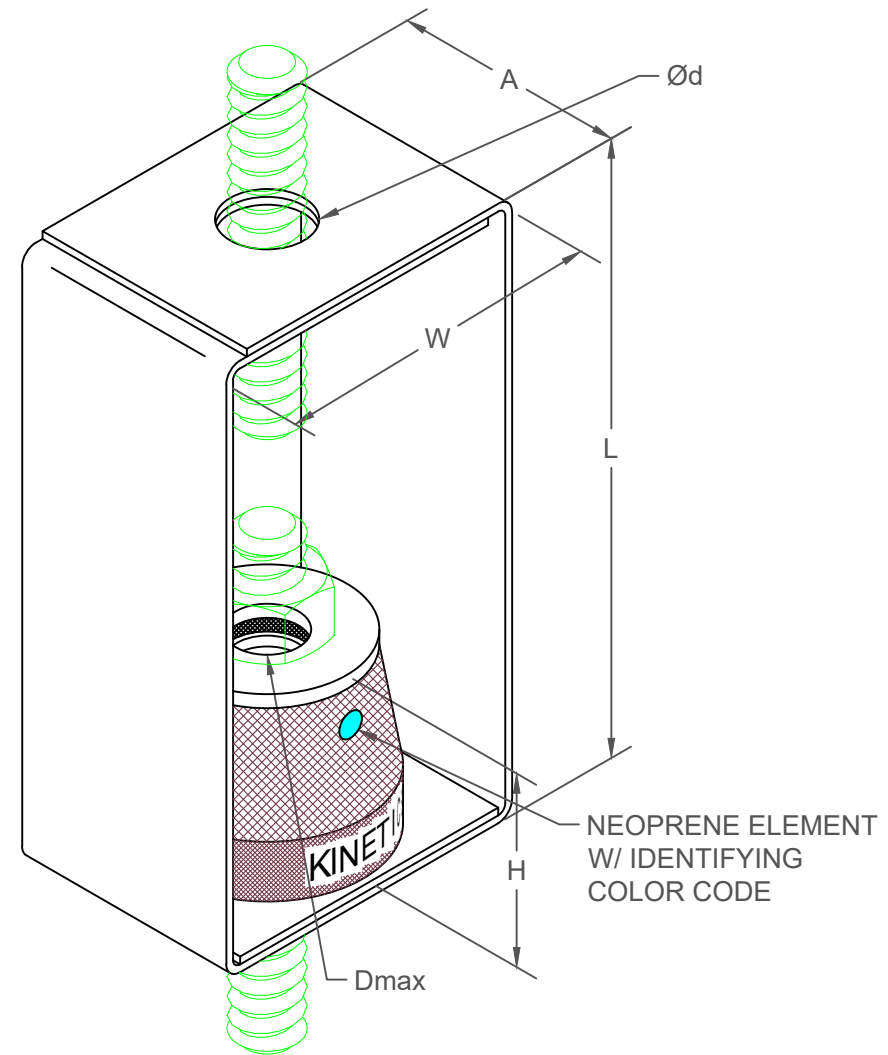

### SPECIFICATIONS:

- HANGER BRACKETS AND LOAD PLATES ARE BRIGHT ZINC PLATED.
- RATED LOADS ARE MAXIMUM CONTINUOUS OPERATING LOADS.
- HANGER BRACKETS WILL CARRY (5) TIMES OVERLOAD WITHOUT FAILURE.
- HANGER BRACKETS WILL ALLOW 30° ROD MISALIGNMENT WITHOUT SHORT CIRCUITING.