

RH-C HANGER

IP UNITS (INCHES AND POUNDS)

TYPE	L	W	A	Dmax	H	Ød
RH-700C/2000C	8.59	5.58	3.63	0.88	2.00	1.13

STANDARD RATINGS

TYPE	SIZE	RATED		ISOLATOR COLOR
		LOAD	DEFL.	
RH	700C	700	0.57	PURPLE
RH	1100C	1100	0.46	YELLOW
RH	2000C	2000	0.53	PINK

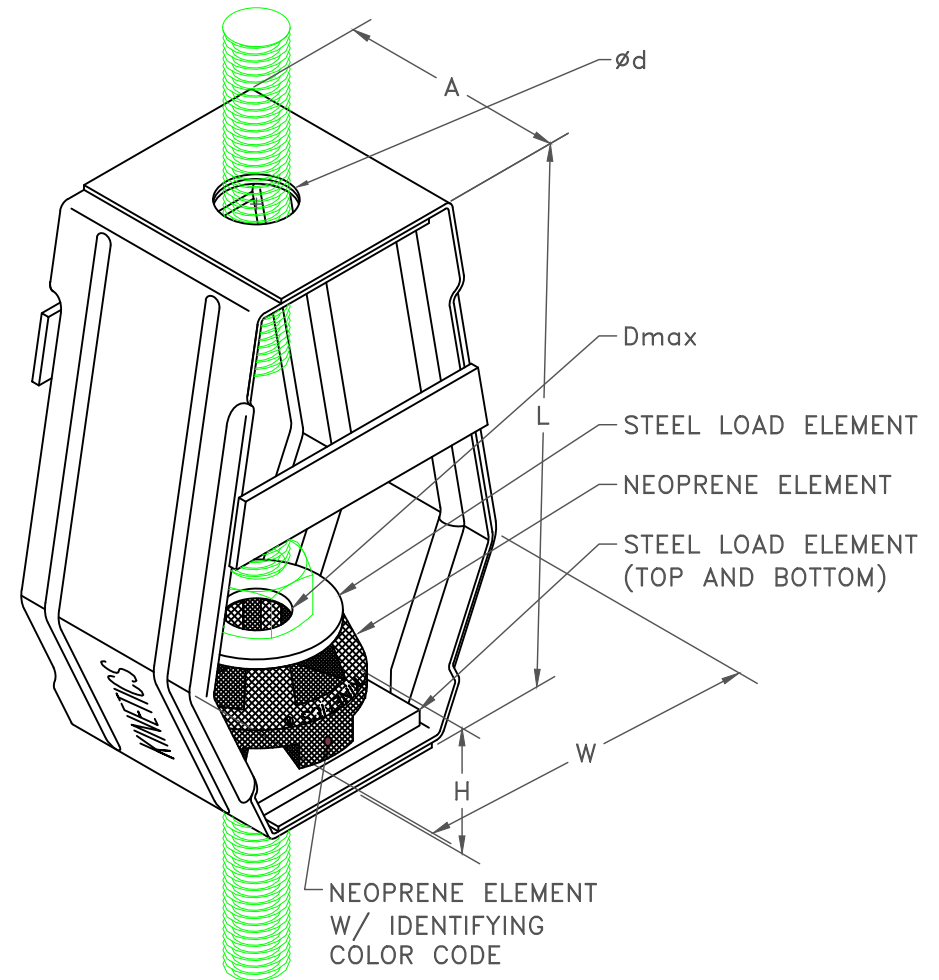

SPECIFICATIONS:

- HANGER BRACKETS AND LOAD PLATES ARE BRIGHT ZINC PLATED.
- RATED LOADS ARE MAXIMUM CONTINUOUS OPERATING LOADS.
- HANGER BRACKETS WILL CARRY (5) TIMES OVERLOAD WITHOUT FAILURE.
- HANGER BRACKETS WILL ALLOW 30° ROD MISALIGNMENT WITHOUT SHORT CIRCUITING.