

# KINETICS NOISE CONTROL TEST REPORT #AT001109

- **KINETICS NOISE CONTROL PRODUCTS:**
  - NONE
- **ACOUSTICAL RATINGS:**
  - ASTC 53\* (\*USING INSUL)
  - AIIIC 29
- **TESTING AGENCY & REPORT NUMBER:**
  - COLLECTIVE TECH / HENDERSON ENGINEERS, INC.
  - PROJECT NUMBER: 1650000859
  - DATED: APRIL 25, 2016

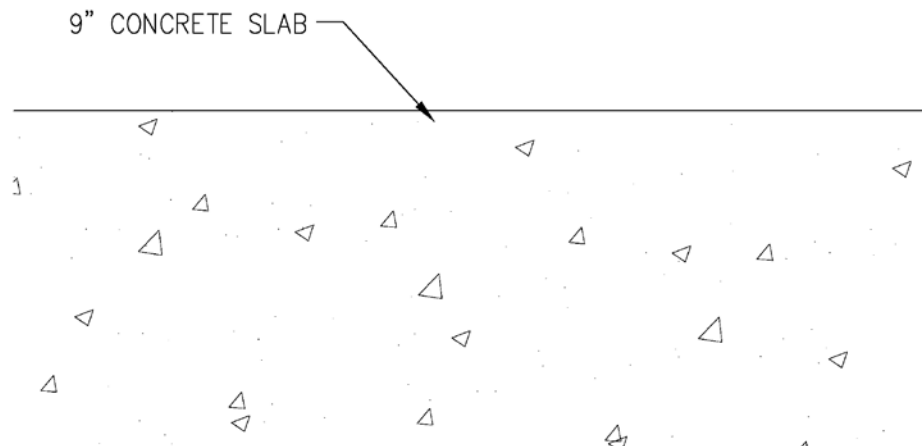

KINETICS DRAWING NUMBER: AT001109A



6300 IRELAN PLACE, DUBLIN OH  
PHONE: 800.959.1229  
FAX: 614.889.0540  
WEB: [WWW.KINETICSNOISE.COM](http://WWW.KINETICSNOISE.COM)  
EMAIL: [ARCHSALES@KINETISNOISE.COM](mailto:ARCHSALES@KINETISNOISE.COM)

# KINETICS NOISE CONTROL TEST REPORT #AT001109

- **KINETICS NOISE CONTROL PRODUCTS:**
  - RIM Q-2-16 ISOLATION MATERIAL
  
- **ACOUSTICAL RATINGS:**
  - ASTC 63
  - AIIIC 57
  
- **TESTING AGENCY & REPORT NUMBER:**
  - COLLECTIVE TECH / HENDERSON ENGINEERS, INC.
  - PROJECT NUMBER: 1650000859
  - DATED: APRIL 25, 2016

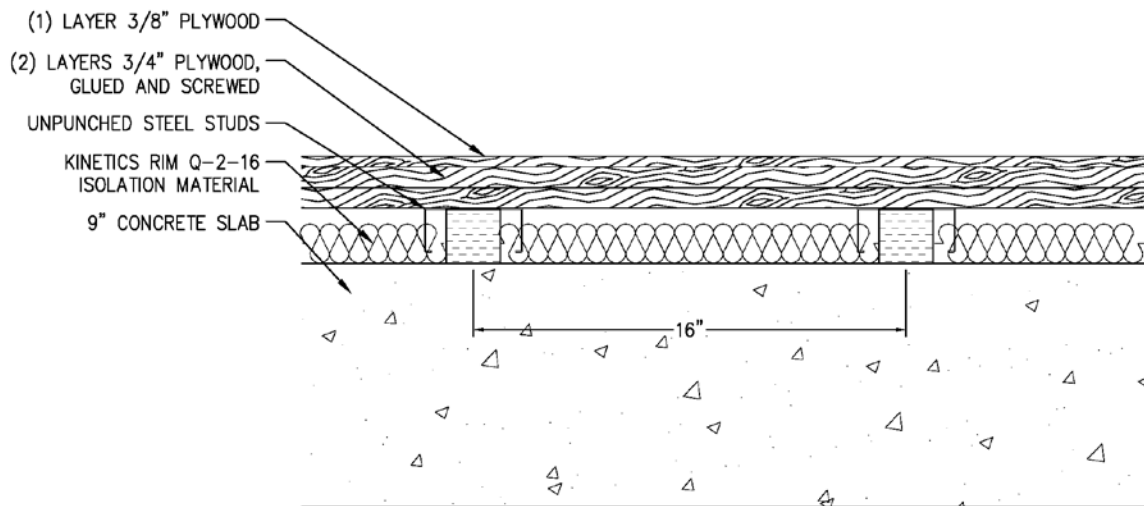

KINETICS DRAWING NUMBER: AT001109B



6300 IRELAN PLACE, DUBLIN OH  
PHONE: 800.959.1229  
FAX: 614.889.0540  
WEB: [www.KINETICSNOISE.COM](http://www.KINETICSNOISE.COM)  
EMAIL: [ARCHSALES@KINETISNOISE.COM](mailto:ARCHSALES@KINETISNOISE.COM)

April 25, 2016

Mr. Steve Manos  
Kinetics Noise Control, Inc.  
6300 Irelan Place  
Dublin, Ohio 43107

RE: KMUW Radio Station  
Acoustical Testing of Studio Floor  
Project No. 1650000859

Dear Steve:

This report summarizes our acoustical testing at KMUW's new station tenant fitout in Wichita, Kansas for your use and records.

## EXECUTIVE SUMMARY

On April 11<sup>th</sup>, 2016, Collective Tech, the acoustics division of Henderson Engineers, visited KMUW radio station's new location at the Smythe Mead building in the Old Town district of Wichita, Kansas. Airborne noise reduction testing and impact isolation testing were conducted in one of the studios for purposes of assessing the noise control capabilities of the Kinetics RIM system, which consisted of the following buildup from top to bottom:

- One (1) layer of 3/8" plywood
- Two (2) layers of 3/4" plywood, glued and screwed
- Steel formed channels (20 ga.), 1-3/8" x 3-5/8"
- 2" Kinetics RIM system
- 9" thick concrete slab

This system produced field ratings of **ASTC-63** and **AIRC-57**. Descriptions and test procedures are provided in the following pages.

## 1.0 DESCRIPTIONS

### 1.1 *Project History*

KMUW (89.1 FM) is a National Public Radio member station located in Wichita, Kansas and owned by Wichita State University. The station just recently moved its operations to the 111 year-old Smythe Mead Building in the Old Town district of Wichita, Kansas. Located at 121 North Mead, the building was constructed in 1905 for use as a warehouse and is listed on the National Register of Historic places by the Department of the Interior.



Originally a three story building, it was damaged by a fire in 1911 which gutted the interiors and caused the collapse of the third story exterior walls. The building burned again in the late 1930's. Currently, the building has load bearing brick masonry exterior walls, concrete framed floor slabs and roof slab, and concrete interior columns.

During construction of KMUW's interior tenant finish, significant deflection was discovered in the structural slab supporting the space. Subsequent structural testing indicated the 9" thick concrete slab had inadequate reinforcing, likely due to cumulative damage from the fires. These conditions caused the design team to revisit many aspects of the tenant fitout to address the structural issues, including redesigning the floating floors in the studio spaces for considerable less load.



### 1.2 Studio Floor Design

The original studio floor design is shown below:

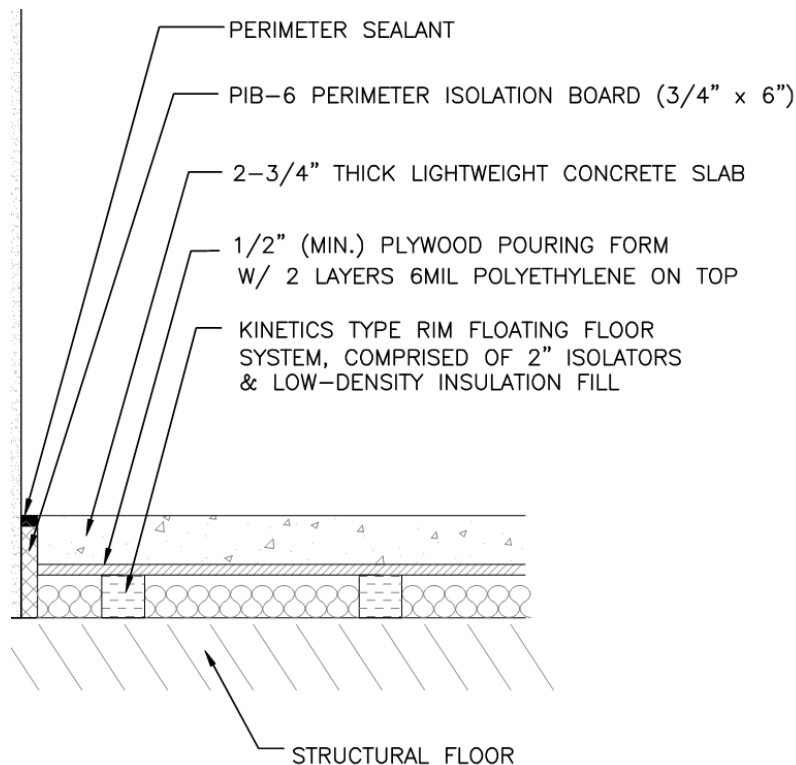

The design intent of this floor-buildup was two-fold: 1) provide a system with very good impact isolation to prevent structure-borne noise from transmitting to the studios as well as tenant areas on the floor below, and 2) decouple the studio spaces from the building structure as much as practically possible to prevent any perception of train noise from the nearby railway from being detected by studio microphones. This was accomplished by installing walls around the studios first, then implementing the floating floors. The ACT grids in the all studios were installed with Kinetics Iso-Grid hangers to isolate the finished ceiling from the roof structure.

The mass of the original Kinetics floating floor system was 24.6 PSF. Through numerous discussions with the architect and structural engineer, it was determined the floating floor of the system had to essentially be “as light as possible”. In addition, a step-down in the structure existed at the middle of the floor which spanned across the entire floor of the building, so there was a limitation to the height of the floating floor due to the necessity to match the depth of the step, which was 5-1/4”. However, the structure sloped from the bottom of the step to exterior walls due to the fire damage, so this added another complication to the new floating floor design. Self-leveling concrete had to be poured over the sloping portion of the structure, which further decreased the maximum weight requirements of the floating floor buildup.

Ultimately, the following floating floor design was approved and installed:

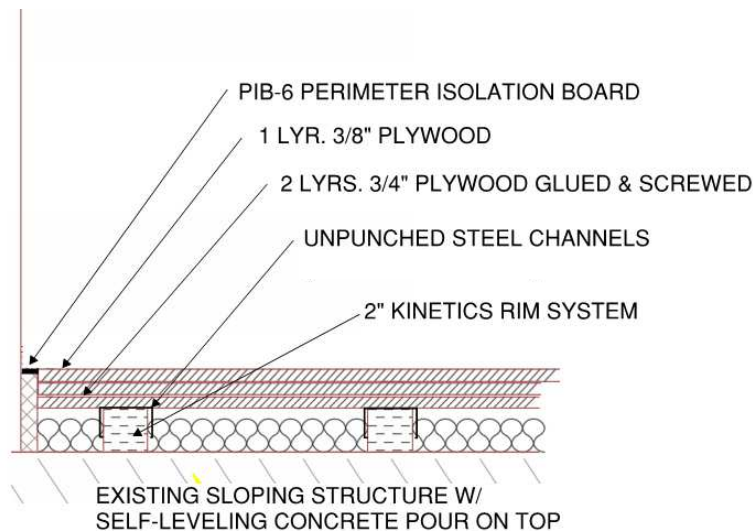

The mass of the floating floor was calculated to be 6.8 PSF. This along with the mass of the self-leveling pour, partitions, and other tenant finish items met the maximum load the structural system could support.

## 2.0 ACOUSTICAL TESTING

Acoustical testing was conducted to obtain the Apparent Impact Insulation Class (AIIC) rating and Apparent Sound Transmission Class (ASTC) rating of the RIM system between a 2<sup>nd</sup> floor studio and tenant space below. In addition, testing was conducted on a portion of the second level, which was not

part of the tenant's space but on the structural slab, for purposes of using it for "delta rating" calculations.

- 2.1 *Instrumentation* – Sound level measurements were obtained with a Larson Davis 831 sound level meter, preamp model PRM831, and 1/2" random-incident condenser microphone Model 377B20. Apparatus was calibrated before and after testing sessions with a Larson Davis CAL200.
- 2.2 *Noise producing equipment* – Tapping tests were conducted with a Look Line EM50 tapping machine ; Noise reduction tests were conducted with a custom mobile sound system consisting of EV DH1A high-frequency driver and JBL 2206H low-frequency driver powered by QSC PL236A, 3600 Watt amplifier and QSC DSP-3 digital signal processing module.
- 2.3 *Procedure*

*AIIC testing (for RIM system testing)* – Conducted in general conformance with *ASTM E1007* and AIIC ratings obtained by *ASTM E989*. The tapping machine was placed in the News Room 2 studio and sound pressure levels were obtained directly below in a first level tenant's storage space. All measurements were averaged to steady-state conditions over approximately 30 second time intervals with negligible intrusive sounds during recording times with meter set to fast.

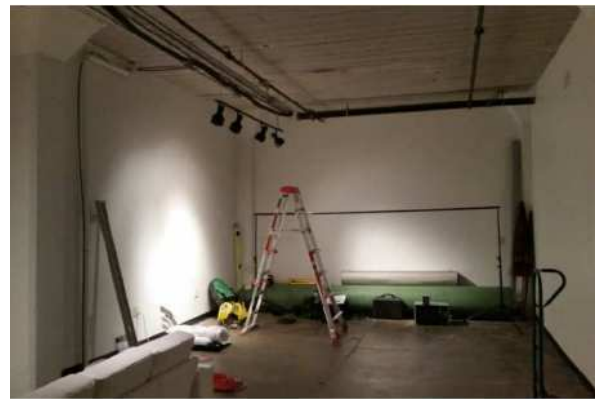

*(Receive location below News Room 2)*

Carpet tile had been installed days before the site visit was conducted. We were able to peel back one of the 24"x24" carpet tiles so impact testing could be conducted on the plywood flooring underneath. A thin layer of plastic was placed down on the plywood to prevent any tapping machine hammers from sticking. Due to the size of the tapping machine and carpet tile, and the desire to do the least amount of modifications to the studio floor for concerns of not being able to reinstall the carpet back to its original finish, we were only able to place the tapping machine in two of the four testing positions described in *ASTM E1007*. All materials met the aging periods as stipulated by *ASTM*.



ASTC testing (for RIM system testing) – Conducted in general conformance with *ASTM E336*. ASTC results obtained by *ASTM E413*. Pink noise served as the noise source in second floor unit living area. Sound pressure levels were obtained in a first floor unit storage space with the meter set to fast response. All measurements were averaged to steady state conditions over approximately 30 to 60 second time intervals using the manually scanned microphone method, with negligible transient sounds during recording times.

Original floor slab testing (for delta calculations) – A portion of the second floor slab was exposed in the Lobby area, with a vacant tenant space below it. The stairway between the first and second level was open to both levels. This arrangement was ideal for the tapping test since associated noise from the Lobby space could be effectively isolated when the receive room door was shut. However, extraneous noise during the airborne test was too much to overcome even with the door closed, so an ASTC rating for the original floor slab could not be obtained.



(Second floor lobby space used for original conditions testing)

Therefore, we used the computer program INSUL to estimate the noise reduction of a 9” concrete slab. Since the concrete structure had been damaged through the years due to fire incidents, lightweight concrete was used in lieu of normal weight to account for any structural degradation and density.

### 3.0 RESULTS & CONCLUSION

The following ratings were obtained:

Kinetics RIM isolation system	<b>ASTC-63</b>	<b>AIRC-57</b>
Original floor structure, 9” concrete slab	<b>ASTC-53*</b>	<b>AIRC-29</b>
Delta (* using INSUL)	10 STC points	28 IIC points

See the attachment for complete normalized one-third octave band tabulations and low-frequency data.

The goal of achieving very good field-IIC performance was achieved. Most notable, it was evident from our two days on-site that train noise could not be detected in the least while standing in the studio wing even though they were passing through on a regular basis. Decoupling all surfaces from the floor and roof structure, building walls, and tenant walls was critical in attaining this goal.

The only negative drawback we could deduce in having such a lightweight floating floor build-up is the floors having a slightly spongy feel while walking in the studios. We predict this would have been

more noticeable if the studios were larger, but in ~80 SF areas it was not enough to be perceived as a problem. The studio engineer and Wichita State University representatives with whom we spoke were not concerned, and very pleased with the finished product, especially not being able to detect train noise.

Steve, please contact us if you have any questions or comments pertaining to our site visit, testing, and reported findings.

Regards,

Collective Tech  
*a division of Henderson Engineers, Inc.*

A handwritten signature in black ink, appearing to read 'JTeel', written in a cursive style.

Jeff Teel  
Associate | Sr. Acoustics Specialist





## Kinetics Testing at KMUW Radio Station Apparent Impact Insulation Class (AIIC)

Source Room: Studio

Receive Room: Room Below

Flooring Assembly: Floor - 3 Layers Plywood on Kinetics RIM System on 9" Concrete

Receive Room Area (sq. ft.)	Receive Room Height (ft.)
640	12

### AIIC: 57

Center Frequency (Hertz)	Receive Room SPL				Average Impact SPL (dB)	Background Noise SPL (dB)	Impact - Background (Δ dB)	Background Correction (+/- dB)	Receive Avg. RT60 (seconds)	Alpha	Room Correction (+/- dB)	Normalized Impact SPL (dB)	Limiting AIIC Contour	Deficiencies
	P1 (dB)	P2 (dB)	P3 (dB)	P4 (dB)										
100	50	52	50	52	51	28	23	0.0	1.6	230	3.3	55	55	0
125	60	59	60	59	60	38	22	0.0	1.7	221	3.1	63	55	8
160	47	49	47	49	48	25	23	0.0	1.6	230	3.3	51	55	0
200	48	46	48	46	47	24	23	0.0	1.6	235	3.4	50	55	0
250	45	45	45	45	45	29	16	0.0	1.5	249	3.6	48	55	0
315	42	44	42	44	43	21	22	0.0	1.6	237	3.4	47	55	0
400	43	44	43	44	43	24	20	0.0	1.7	218	3.1	46	54	0
500	39	39	39	39	39	17	22	0.0	1.6	242	3.5	43	53	0
630	35	36	35	36	35	15	20	0.0	1.6	241	3.5	39	52	0
800	30	30	30	30	30	15	15	0.0	1.6	242	3.5	34	51	0
1000	29	29	29	29	29	17	12	0.0	1.4	260	3.8	33	50	0
1250	26	27	26	27	26	17	9	-0.6	1.4	269	4.0	30	47	0
1600	25	26	25	26	25	19	7	-1.1	1.3	289	4.3	29	44	0
2000	24	25	24	25	25	17	8	-0.7	1.1	346	5.1	29	41	0
2500	22	23	22	23	23	12	11	0.0	1.0	376	5.4	28	38	0
3150	20	21	20	21	21	16	5	-2.0	1.1	355	5.2	24	35	0

Max Deficiency = 8  
Total Deficiencies = 8

# Kinetics Testing at KMUW Radio

## Apparent Impact Insulation Class (AIIC)

Source Room: Studio

Receive Room: Room Below

Flooring Assembly: Floor - 3 Layers Plywood on Kinetics RIM System on  
9" Concrete

**AIIC: 57**

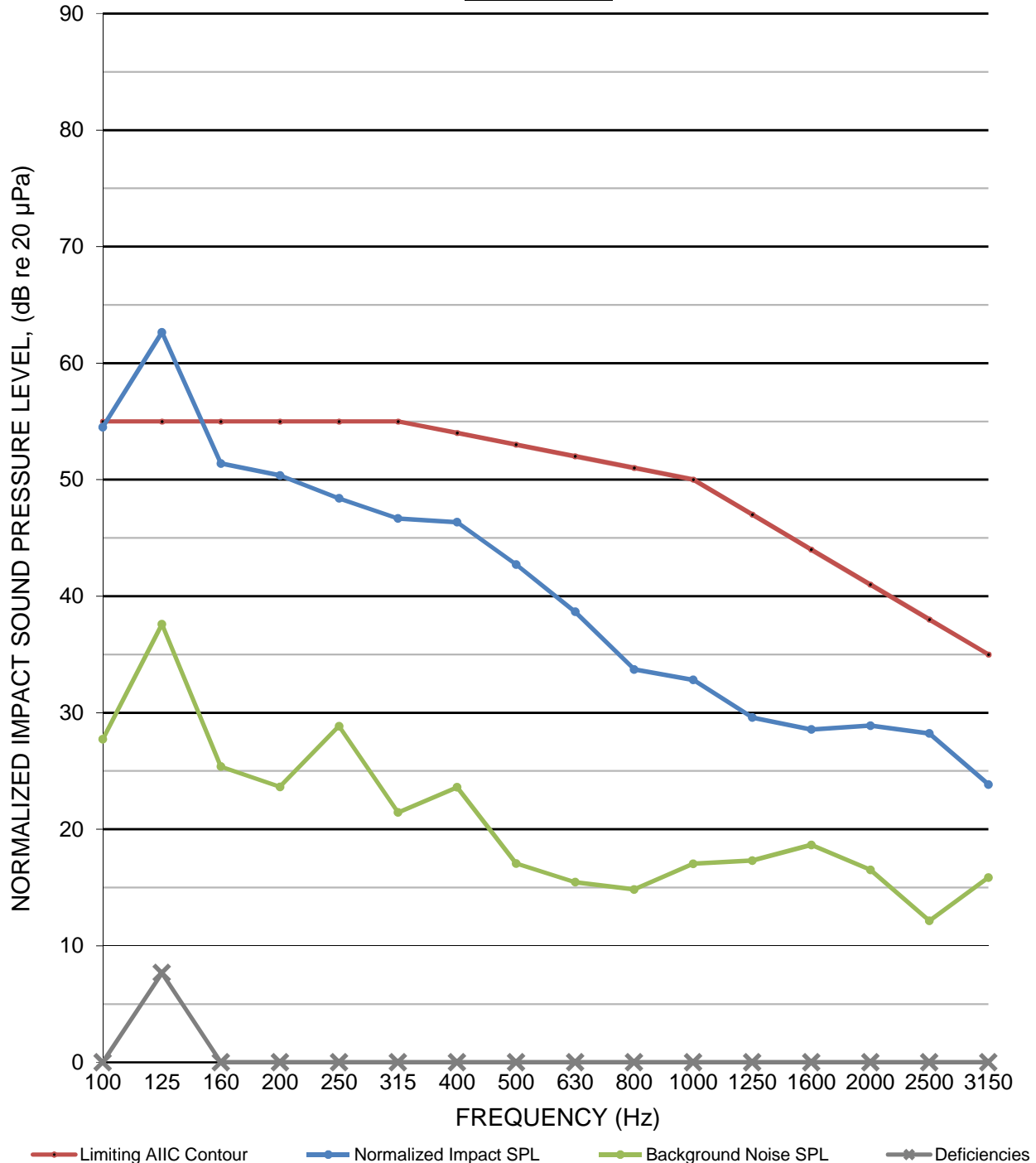



## Kinetics Testing at KMUW Radio Station Apparent Impact Insulation Class (AIIC)

Source Room: 2nd Floor  
Receive Room: Lobby Space Below  
Flooring Assembly: Floor - Original 9" Concrete

Receive Room Area (sq. ft.)	Receive Room Height (ft.)
224	12

### AIIC: 29

Center Frequency (Hertz)	Receive Room SPL				Average Impact SPL (dB)	Background Noise SPL (dB)	Impact - Background (Δ dB)	Background Correction (+/- dB)	Receive Avg. RT60 (seconds)	Alpha	Room Correction (+/- dB)	Normalized Impact SPL (dB)	Limiting AIIC Contour	Deficiencies
	P1 (dB)	P2 (dB)	P3 (dB)	P4 (dB)										
100	56	56	57	58	57	28	29	0.0	1.0	127	0.7	58	83	0
125	60	60	61	60	60	38	23	0.0	1.0	127	0.7	61	83	0
160	61	63	62	62	62	25	37	0.0	1.1	123	0.6	63	83	0
200	62	62	62	63	62	24	38	0.0	1.0	132	0.9	63	83	0
250	63	63	63	63	63	29	34	0.0	0.9	141	1.2	64	83	0
315	64	63	64	64	64	21	43	0.0	1.0	138	1.1	65	83	0
400	66	66	66	66	66	24	42	0.0	1.1	115	0.3	66	82	0
500	67	67	67	66	67	17	50	0.0	1.1	115	0.3	67	81	0
630	68	68	67	68	68	15	52	0.0	1.2	114	0.2	68	80	0
800	69	69	69	69	69	15	54	0.0	1.2	106	-0.1	69	79	0
1000	69	70	70	69	70	17	53	0.0	1.2	106	-0.1	70	78	0
1250	70	70	69	69	70	17	53	0.0	1.3	104	-0.2	70	75	0
1600	71	71	71	70	71	19	52	0.0	1.2	110	0.1	71	72	0
2000	71	71	70	70	71	17	54	0.0	1.1	117	0.3	71	69	2
2500	70	71	71	71	71	12	59	0.0	1.2	114	0.2	71	66	5
3150	70	70	70	71	70	16	54	0.0	1.2	112	0.2	70	63	7

Max Deficiency = 7  
Total Deficiencies = 14

# Kinetics Testing at KMUW Radio

## Apparent Impact Insulation Class (AIIC)

Source Room: 2nd Floor  
 Receive Room: Lobby Space Below  
 Flooring Assembly: Floor - Original 9" Concrete

**AIIC: 29**

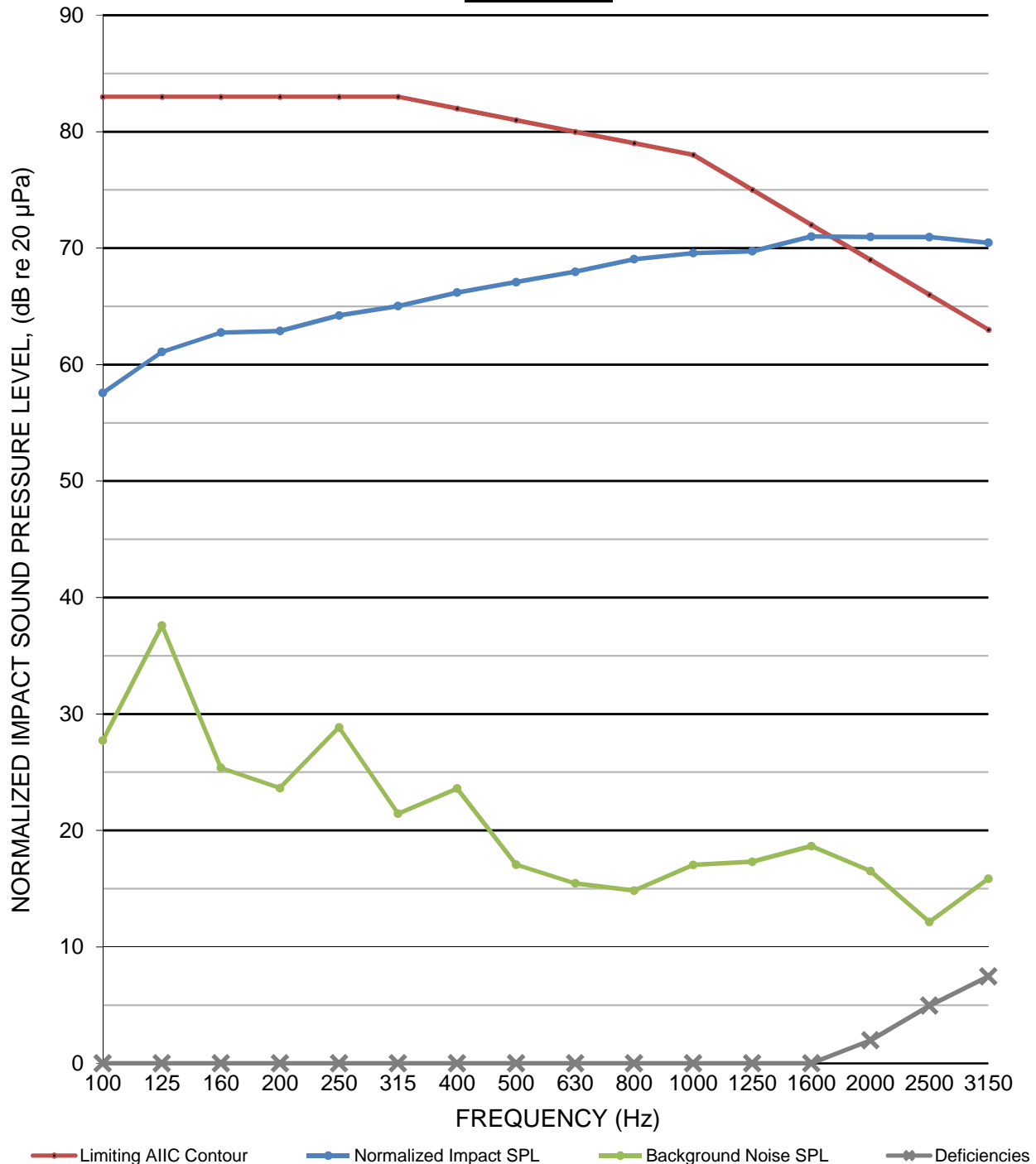



## Kinetics Testing at KMW Radio Station Apparent Sound Transmission Class (ASTC)

Source Room: Studio  
Receive Room: Room Below  
Assembly: Floor - 3 Layers Plywood on Kinetics RIM System on 9" Concrete

Common Surface Area (sq. ft.)	Additional Room Dimension (ft.)
640	12

### ASTC: 63

Center Frequency (Hertz)	Source Room SPL (dB)	Receive Room SPL (dB)	NR Noise Reduction	Background Noise SPL (dB)	Receive - Background (Δ dB)	Background Correction (+/- dB)	Receive Avg. RT60 (seconds)	Alpha	Room Correction (+/- dB)	NNR Normalized NR	ATL Apparent Transmissio	Limiting ASTC Contour	Deficiencies
125	95	60.0	35	38	22	0.0	1.7	221	5	40	39	47	8
160	103	44.0	59	25	19	0.0	1.6	230	4	64	63	50	0
200	102	39.7	62	24	16	0.0	1.6	235	4	67	66	53	0
250	107	40.4	67	29	12	0.0	1.5	249	4	72	71	56	0
315	107	38.3	69	21	17	0.0	1.6	237	4	74	73	59	0
400	107	35.0	72	24	11	0.0	1.7	218	5	78	77	62	0
500	108	33.9	74	17	17	0.0	1.6	242	4	79	78	63	0
630	103	31.0	72	15	16	0.0	1.6	241	4	77	76	64	0
800	100	25.7	75	15	11	0.0	1.6	242	4	80	79	65	0
1000	101	28.0	73	17	11	0.0	1.4	260	4	78	77	66	0
1250	101	24.8	76	17	8	-0.1	1.4	269	4	80	80	67	0
1600	101	24.4	76	19	6	-0.1	1.3	289	3	80	80	67	0
2000	100	24.0	76	17	8	-0.1	1.1	346	3	79	78	67	0
2500	99	22.7	76	12	11	0.0	1.0	376	2	79	79	67	0
3150	99	19.8	79	16	4	-2.0	1.1	355	3	80	79	67	0
4000	97	17.5	79	12	5	-0.3	1.0	364	2	82	82	67	0

Max Deficiency = 8  
Total Deficiencies = 8

# Kinetics Testing at KMUW Radio

## Apparent Sound Transmission Class

Source Room: Studio

Receive Room: Room Below

Assembly: Floor - 3 Layers Plywood on Kinetics RIM System on 9" Concrete

**ASTC: 63**

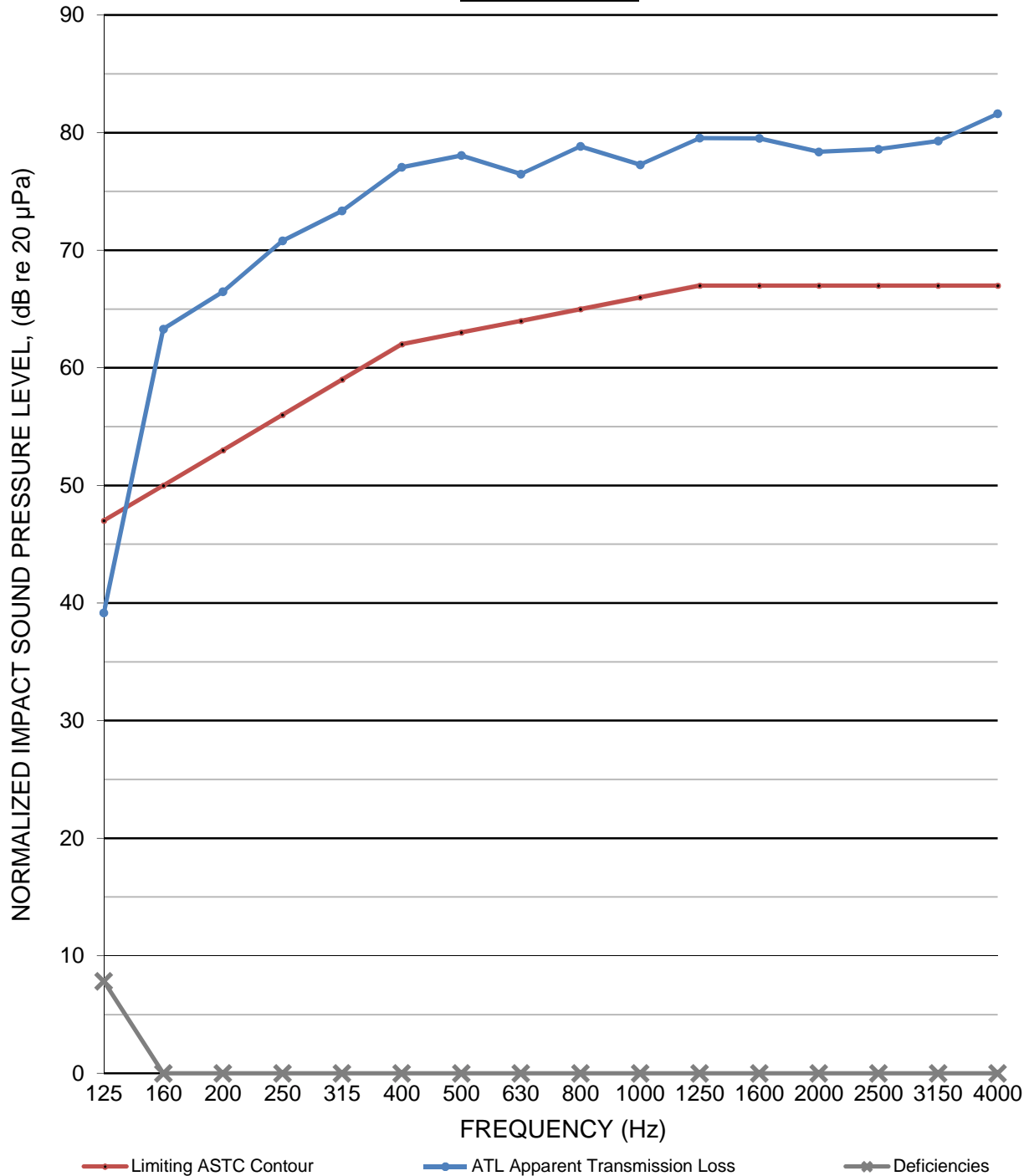



**One-Third Octave Band Delta**

Assembly: 3 Layers of Plywood on 2” Kinetics RIM System on 9” Concrete

The table below indicates the delta between before and after tests for one-third octave band data, from 20 Hz to 5,000 Hz.

Δ ASTC: 10 points (ASTC 63 vs 53)

Δ AIIIC: 28 points (AIIIC 57 vs 29)

Frequency (Hz)	Δ FTL (for ASTC)	Δ SPL (for AIIIC)
20	17	7
25	17	-4
31.5	14	-5
40	16	2
50	14	1
63	25	7
80	26	8
100	21	6
125	6	1
160	29	14
200	34	15
250	39	18
315	41	21
400	43	23
500	45	28
630	42	33
800	46	39
1000	44	41
1250	46	44
1600	47	46
2000	46	46
2500	47	48
3150	48	50
4000	47	51
5000	48	53