

SL 25 mm DEFLECTION ISOLATOR

S-I UNITS (mm AND kg)

TYPE	A	B	C	D	E	F	G	H	L	W
35A/805A	143	27	8	10	-	-	-	89	156	54
50C/3500C	203	44	11	16	51	191	11	127	229	89

NOTE: ALL MOUNTING DIMENSIONS SYMMETRIC ABOUT ISOLATOR CENTER

STANDARD RATINGS		SPRING COIL					
		COLOR		FREE		RATED	
TYPE	SIZE	OUTER	INNER	HT.	O.D.	LOAD	DEFL.
SL	35A	BLUE		81	44	16	39
SL	70A	GREEN		81	44	32	35
SL	120A	GRAY		81	44	54	30
SL	220A	BROWN		81	44	100	27
SL	370A	ORANGE		81	44	168	24
SL	500A	BEIGE		81	44	227	25
SL	600A	CHROME		81	44	272	25
SL	700A	BEIGE	WHITE	81	44	318	25
SL	805A	CHROME	WHITE	81	44	365	26
SL	50C	BEIGE		107	76	23	25
SL	100C	CHROME		107	76	45	25
SL	250C	BLUE		107	76	113	45
SL	450C	GREEN		107	76	204	39
SL	625C	BLACK		107	76	283	37
SL	800C	GRAY		107	76	363	33
SL	1000C	RED		107	76	454	29
SL	1250C	BROWN		107	76	567	28
SL	1700C	ORANGE		107	76	771	24
SL	2200C	ORANGE	GRAY	107	76	998	26
SL	2465C	BLUE		107	76	1118	25
SL	2865C	BLUE	GRAY	107	76	1300	25
SL	3500C	BLUE	BROWN	107	76	1588	25

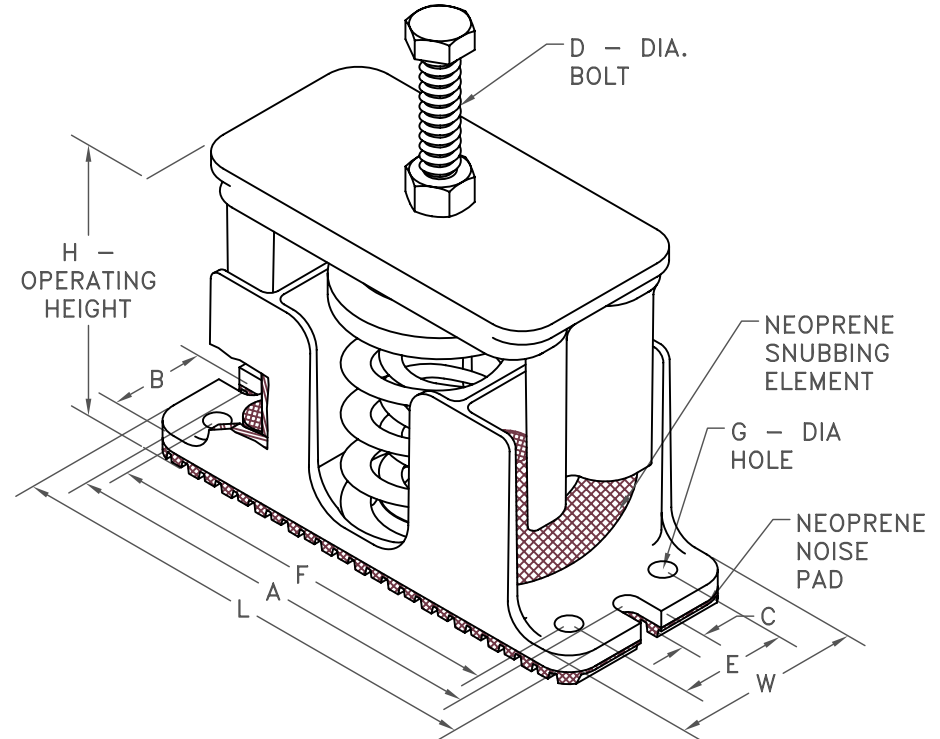

SPECIFICATIONS:

- HOUSED COIL SPRING ISOLATOR WITH INTERNAL SNUBBERS.
- POWDER COATED STEEL SPRING ELEMENTS.
- OTHER METALLIC HARDWARE IS BRIGHT ZINC PLATED.
- 35A/805A HOUSINGS ARE CAST ALUMINUM, 50C/3500C ARE CAST IRON.
- MINIMUM OVERLOAD OF 50%.
- MINIMUM Kx/Ky RATIO OF 1.0.
- ALL ELEMENTS SAFE AT SOLID LOADING.
- ALL THREADED MEMBERS ARE AMERICAN STANDARD.



KINETICS NOISE CONTROL, INC
 6300 IRELAN PL,
 DUBLIN, OH 43017 USA
 Ph: 614 889-0480, Fax: 614 889-0540
 www.kineticsnoise.com

Model: SL-35A/3500C

By: BB
 Date: 02/11/08
 Revised: /

Drawing No: S-01.24-11 METRIC