

SLI 25 mm DEFLECTION ISOLATOR

S-I UNITS (mm AND kg)

TYPE	A	B	C	E	F	G	H	L	W
35A/805A	143	27	8	-	-	-	103	156	54
50C/3500C	203	44	11	51	191	11	141	229	89

NOTE: ALL MOUNTING DIMENSIONS SYMMETRIC ABOUT ISOLATOR CENTER

STANDARD RATINGS		SPRING COIL					
		COLOR		FREE		RATED	
TYPE	SIZE	OUTER	INNER	HT.	O.D.	LOAD	DEFL.
SLI	35A	BLUE		81	44	16	39
SLI	70A	GREEN		81	44	32	35
SLI	120A	GRAY		81	44	54	30
SLI	220A	BROWN		81	44	100	27
SLI	370A	ORANGE		81	44	168	24
SLI	500A	BEIGE		81	44	227	25
SLI	600A	CHROME		81	44	272	25
SLI	700A	BEIGE	WHITE	81	44	318	25
SLI	805A	CHROME	WHITE	81	44	365	26
SLI	50C	BEIGE		107	76	23	25
SLI	100C	CHROME		107	76	45	25
SLI	250C	BLUE		107	76	113	45
SLI	450C	GREEN		107	76	204	39
SLI	625C	BLACK		107	76	283	37
SLI	800C	GRAY		107	76	363	33
SLI	1000C	RED		107	76	454	29
SLI	1250C	BROWN		107	76	567	28
SLI	1700C	ORANGE		107	76	771	24
SLI	2200C	ORANGE	GRAY	107	76	998	26
SLI	2465C	BLUE		107	76	1118	25
SLI	2865C	BLUE	GRAY	107	76	1300	25
SLI	3500C	BLUE	BROWN	107	76	1588	25

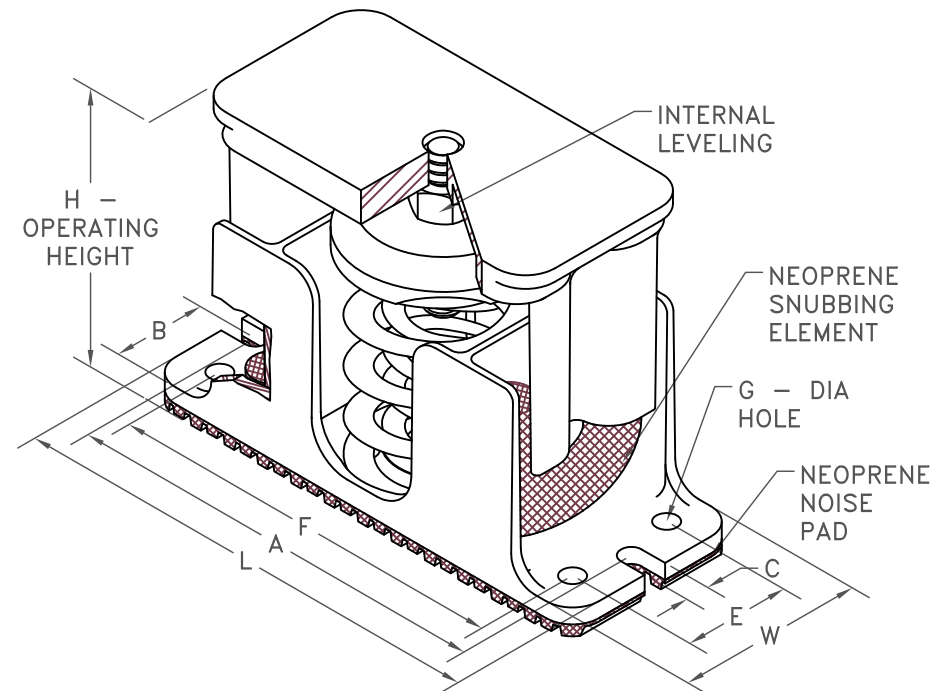

SPECIFICATIONS:

- HOUSED COIL SPRING ISOLATOR WITH INTERNAL SNUBBERS.
- POWDER COATED STEEL SPRING ELEMENTS.
- OTHER METALLIC HARDWARE IS BRIGHT ZINC PLATED.
- 35A/805A HOUSINGS ARE CAST ALUMINUM, 50C/3500C ARE CAST IRON.
- MINIMUM OVERLOAD OF 50%.
- MINIMUM K_x/K_y RATIO OF 1.0.
- ALL ELEMENTS SAFE AT SOLID LOADING.
- ALL THREADED MEMBERS ARE AMERICAN STANDARD.



KINETICS NOISE CONTROL, INC
 6300 IRELAN PL,
 DUBLIN, OH 43017 USA
 Ph: 614 889-0480, Fax: 614 889-0540
www.kineticsnoise.com

Model:
SLI-35A/3500C

By: **BB**
 Date: **02/11/08**
 Revised: **/**

Drawing No:
S-01.26-11 METRIC