

INSTALLATION INSTRUCTIONS FOR SRH HANGER

- 1) LOCATE EACH HANGER INTO POSITION BASED ON SUBMITTAL DRAWING, USING COLOR CODED SPRINGS AS IDENTIFICATION.
- 2) ATTACH HANGER BOX TO UPPER HANGING ROD AS SHOWN IN SKETCH.
- 3) ATTACH EQUIPMENT TO LOWER HANGING ROD AS SHOWN IN SKETCH.
- 4) IF NECESSARY, ADJUST EQUIPMENT LEVEL BY THE LEVEL ADJUSTMENT NUT ON THE TOP OF THE COIL SPRING AS SHOWN IN THE SKETCH. THIS STEP SHOULD BE PERFORMED AFTER THE EQUIPMENT IS BROUGHT UP TO ITS OPERATING WEIGHT.
- 5) CHECK TO ENSURE ADEQUATE ALIGNMENT BETWEEN THE LARGE HOLE IN THE HANGER BOX (AT THE BASE OF THE SPRING) AND THE LOWER HANGING ROD.

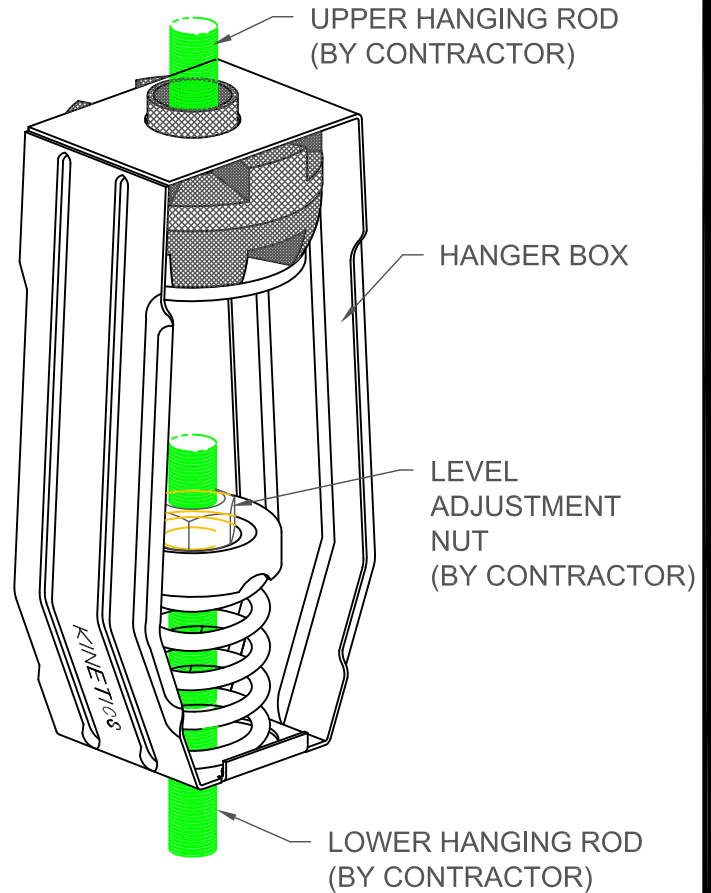

FOR SEISMIC APPLICATIONS

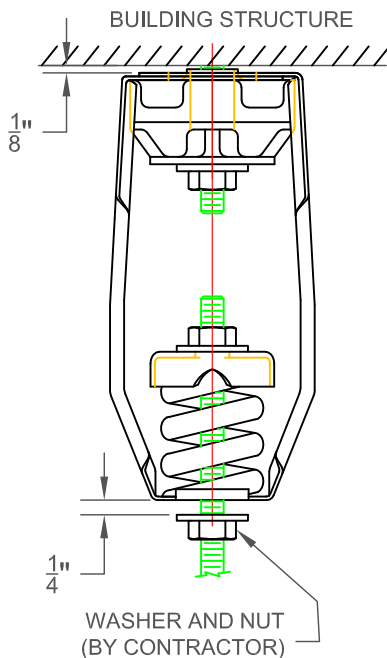

- A) HANGER BOX MUST BE ATTACHED WITH APPROX. $\frac{1}{8}$ " CLEARANCE BETWEEN HANGER BOX AND BUILDING STRUCTURE.
- B) INCLUDE AN ADDITIONAL WASHER AND NUT ON THE LOWER HANGER ROD BELOW THE HANGER BOX.
- C) THE WASHER O.D. MUST BE LARGER THAN THE ROD HOLE IN THE BOTTOM OF THE HANGER BOX.
- D) WHEN THE SYSTEM IS AT OPERATING WEIGHT, ADJUST THE LOWER NUT UNTIL THE WASHER IS $\frac{1}{4}$ " OFF THE BOTTOM OF THE HANGER BOX.

NOTE: FOR SEISMIC APPLICATIONS, RESTRAINT CABLES ARE REQUIRED, AND ARE AVAILABLE SEPARATELY.

