

CURB CONNECTIONS MADE BY USING THREE (3) No. 12-14 X 2.5 SELF DRILLING TEK SCREWS BY KINETICS.

NOTES:

- 1.) PILOT HOLES MAY BE MADE WITH A No. 13 (Ø0.185) DRILL.
- 2.) KSCM-2 SEISMIC RESTRAINT BRACKET #2 MAY BE TRIMMED TO FIT.
- 3.) CAULKING OF EQUIPMENT PENETRATIONS TO BE BY OTHERS.

REFERENCE DRWGS.
INS-88.071-19A & 19C AND S-88.071-19A

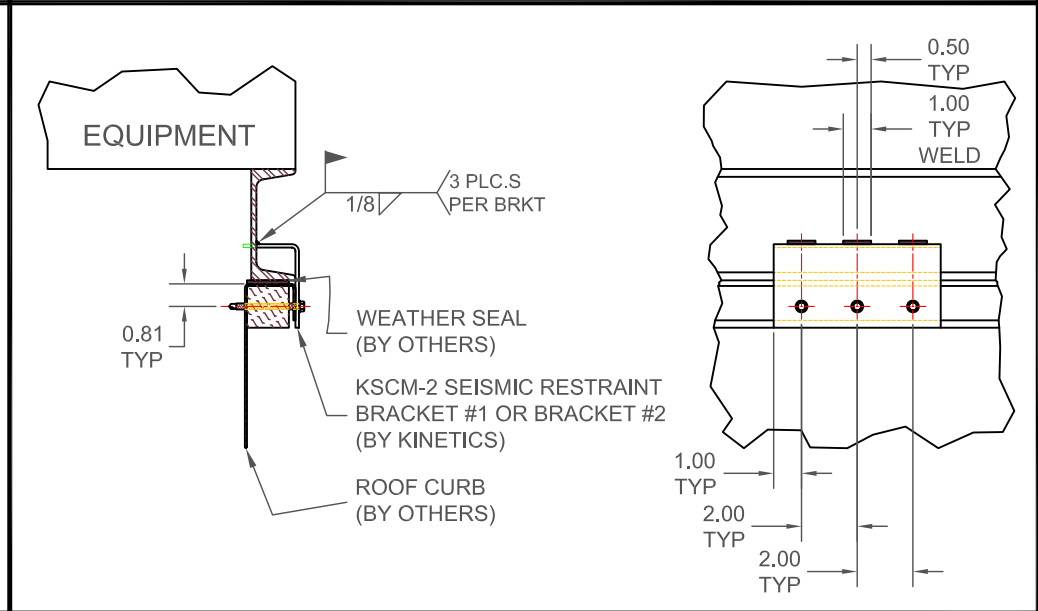
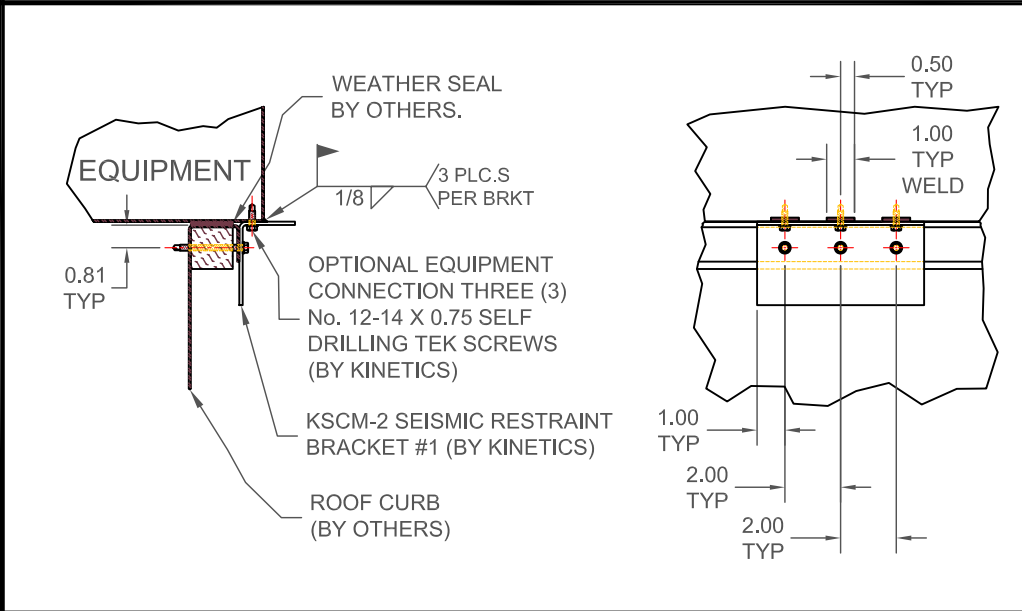
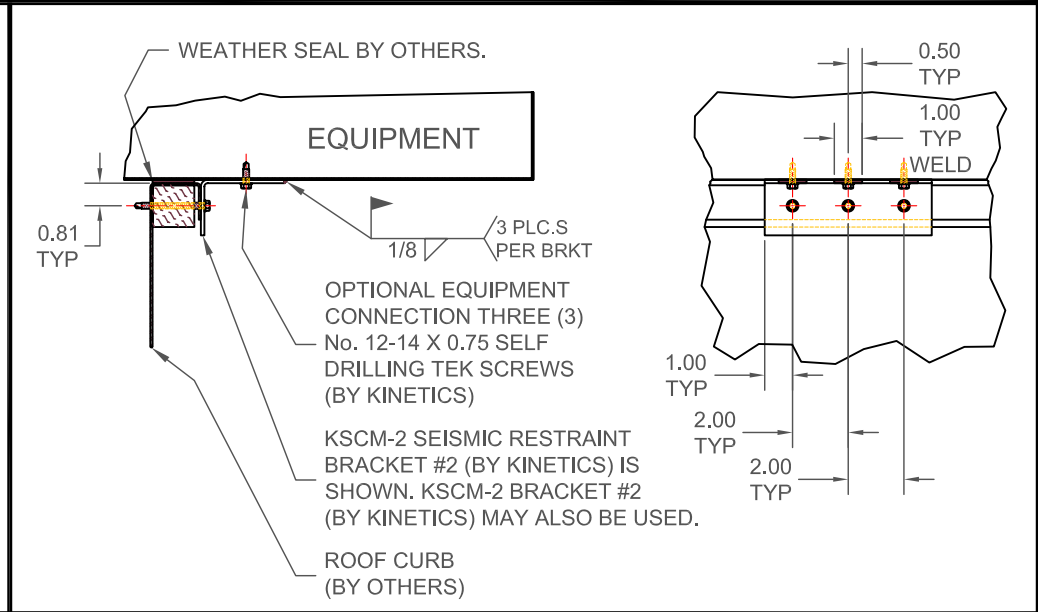
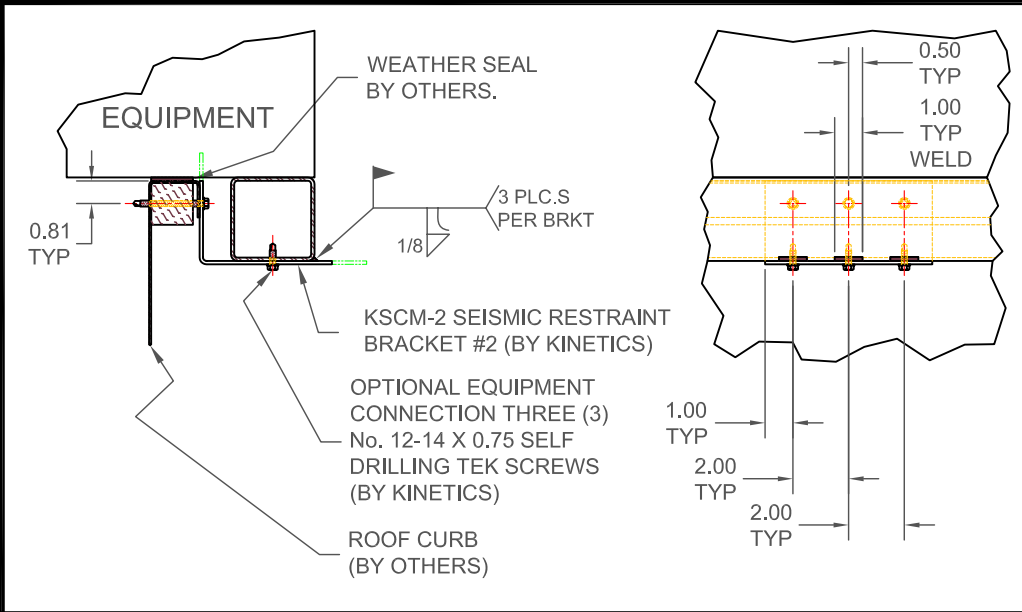

TITLE
KSCM-2 SEISMIC BRACKET KIT INSTALLATION OPTIONS GUIDE

LAST DATE REVISED
08/30/04

REVISED BY
BB

DRAWING NO.
INS-88.071-19B

INS