

# FDS 2" DEFLECTION ISOLATOR

IP UNITS (INCHES AND POUNDS)

TYPE	L	W	T	A	E	D	H	TT	Z
2-100B/1975B	7.00	4.00	0.41	0.75	2.00	0.69	7.50	0.38	0.38

STANDARD RATINGS		SPRING COIL					
TYPE	SIZE	COLOR		FREE		RATED	
		OUTER	INNER	HT.	O.D.	LOAD	DEFL.
FDS	2-100B	BLUE		6.09	3.50	100	2.00
FDS	2-135B	BLUE		6.09	3.50	135	2.00
FDS	2-185B	BLUE		6.09	3.50	185	2.00
FDS	2-225B	BLUE	BLUE	6.09	3.50	225	2.00
FDS	2-250B	BLUE		6.09	3.50	250	2.00
FDS	2-375B	BLUE	BLUE	6.09	3.50	375	2.00
FDS	2-500B	BLUE		6.09	3.50	500	2.00
FDS	2-625B	BLUE	BLUE	6.09	3.50	625	2.00
FDS	2-750B	BLUE		6.09	3.50	750	2.00
FDS	2-875B	BLUE	BLUE	6.09	3.50	875	2.00
FDS	2-995B	BLUE		6.09	3.50	995	2.00
FDS	2-1120B	BLUE	BLUE	6.09	3.50	1120	2.00
FDS	2-1400B	BLUE	BLUE	6.09	3.50	1400	2.01
FDS	2-1600B	BLUE		6.09	3.50	1600	2.00
FDS	2-1975B	BLUE	BLUE	6.09	3.50	1975	1.98

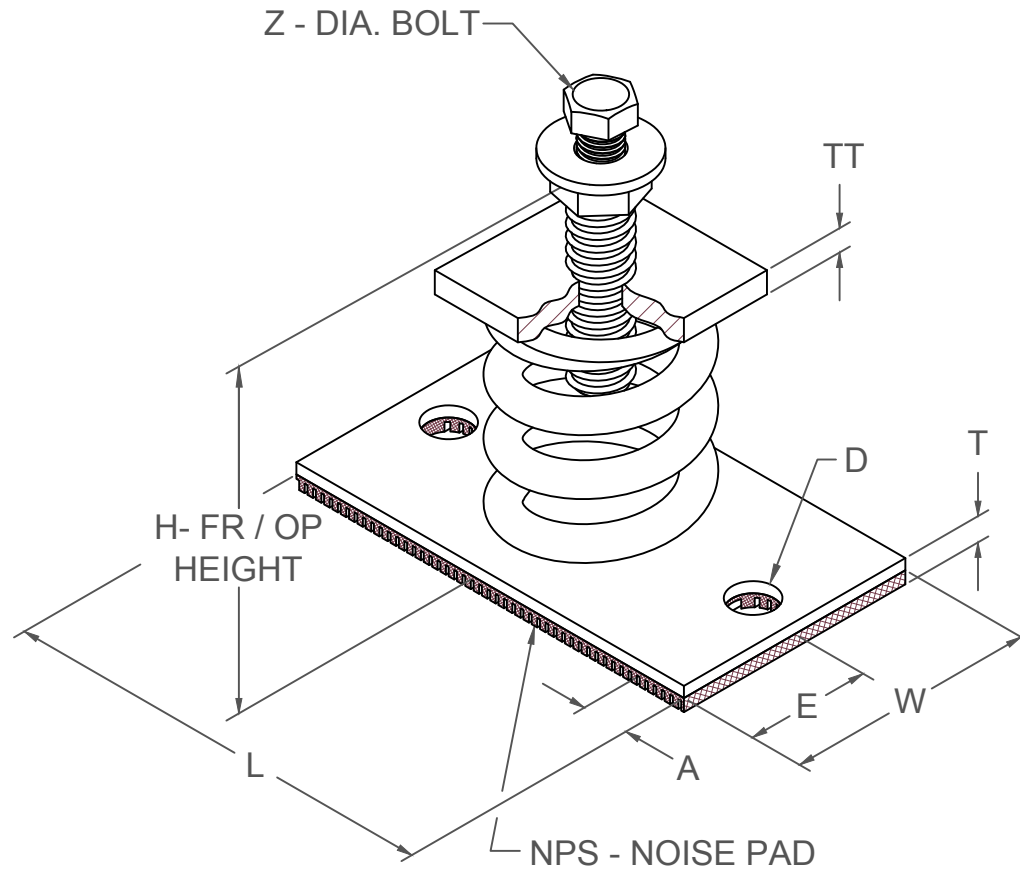

### SPECIFICATIONS:

- LOAD PLATES ARE AFFIXED TO COIL SPRING.
- FREE STANDING COIL SPRING ISOLATOR.
- FDS-B ISOLATORS ARE PAINTED.
- HARDWARE IS BRIGHT ZINC PLATED.
- MINIMUM OVERLOAD OF 50%.
- MINIMUM K<sub>x</sub>/K<sub>y</sub> RATIO OF 1.0.
- ALL ELEMENTS SAFE AT SOLID LOADING.
- ALL THREADED MEMBERS ARE AMERICAN STANDARD.
- FDS-B ISOLATORS ARE NOT SEISMICALLY RATED AND CANNOT BE COUNTED ON TO PROVIDE RESTRAINT IN SEISMIC OR WIND APPLICATIONS.



KINETICS NOISE CONTROL, INC  
 6300 IRELAN PL,  
 DUBLIN, OH 43017 USA  
 Ph: 614 889-0480, Fax: 614 889-0540  
 www.kineticsnoise.com

Model:  
**FDS-2-100B/1975B**

By: **JMJ**  
 Date: **04/16/02**  
 Revised: **05/21/15 / BB**

Drawing No:  
**S-01.20-22**