

# FMS 1" DEFLECTION ISOLATOR

IP UNITS (INCHES AND POUNDS)

TYPE	L	W	A	H	T	Z
1-3400/7000	8.50	4.00	5.25	7.94	0.22	0.75

STANDARD RATINGS		SPRING COIL						APPLICABLE MODELS
TYPE	SIZE	COLOR		FREE		RATED		
		OUTER	INNER	HT.	O.D.	LOAD	DEFL.	
FMS	1-3400	ORANGE		4.20	3.00	3400	0.95	C, D, E
FMS	1-4200	ORANGE	GRAY	4.20	3.00	4200	0.96	C, D, E
FMS	1-4930	BLUE		4.20	3.00	4930	1.00	C, D, E
FMS	1-5730	BLUE	GRAY	4.20	3.00	5730	1.00	C, D, E
FMS	1-7000	BLUE	BROWN	4.20	3.00	7000	1.00	D, E

NOTE: FMS RESTRAINT SHOWN IS NOT TO SCALE. ACTUAL SIZE AND SHAPE MAY VARY. SEE CORRESPONDING FMS RESTRAINT SUBMITTAL FOR ACTUAL DIMENSIONS.

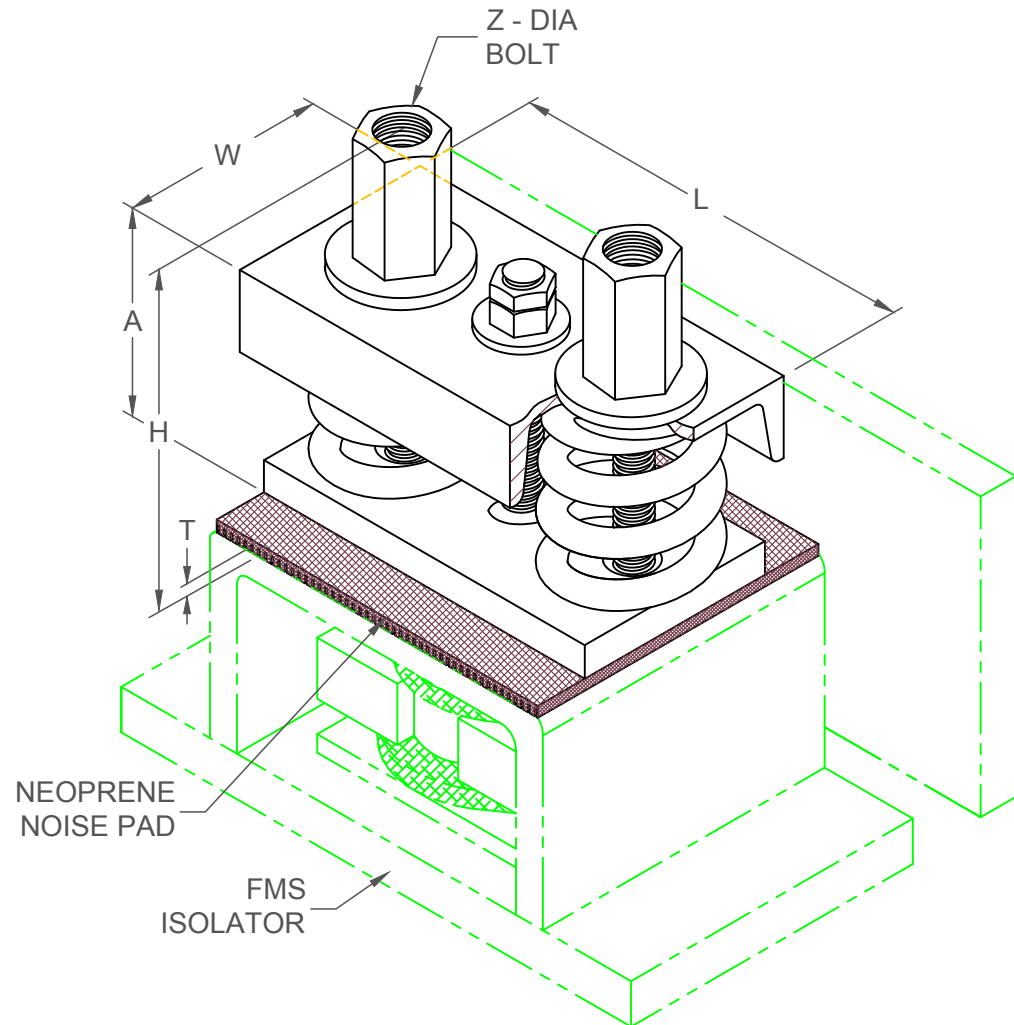

### SPECIFICATIONS:

- FREE STANDING COIL SPRING ISOLATOR.
- POWDER COATED SPRING ELEMENTS AND LOAD PLATES.
- OTHER METALLIC COMPONENTS ARE BRIGHT ZINC PLATED.
- MINIMUM OVERLOAD OF 50%.
- MINIMUM Kx/Ky RATIO OF 1.0.
- ALL ELEMENTS SAFE AT SOLID LOADING.
- ALL THREADED MEMBERS ARE AMERICAN STANDARD.