

S-I UNITS (mm AND kg)																			
TYPE	DIMENSION																		
	A	B	C	D	E	F	G	H	J	K	L	M	N	P	Q	R	S	T	U
FMSB	102	194	127	241	10	13	98	11	14	19	203	19	76	10	83	10	175	32	30

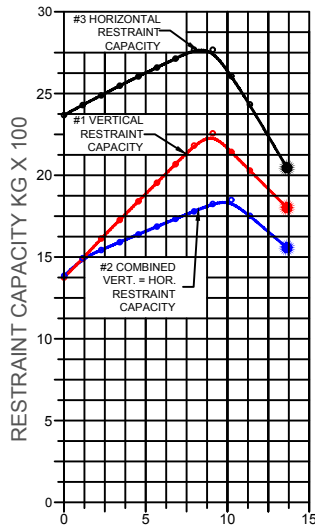

FIGURE 2  
STEEL ATTACHMENT

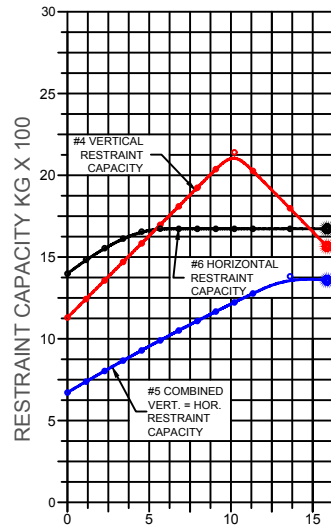

FIGURE 3  
CONCRETE ATTACHMENT

FMSB REQUIRES 10 DIA X 64 MIN. EMBED ANCHORS IN CONCRETE (ALLOWABLE LOADS BASED ON 20700 KPA MIN CONCRETE)  
FMSB ANCHOR BOLT TORQUE - 27 NM, PULL TEST - 550 KG

### RESTRAINT CAPACITY ENVELOPE GENERATION

#### RESTRAINT ONLY (NO SPRING ELEMENT)

- 1) READ THE ANCHORED (CONCRETE) OR BOLTED (STEEL) ENVELOPES DIRECTLY FROM FIGURE 1.

#### RESTRAINT WITH SPRING SUPPORT ELEMENT (ISOLATOR/RESTRAINT)

- 1) DETERMINE THE MAXIMUM EQUIPMENT LOAD SUPPORTED BY THE ISOLATOR(S)
- 2) IF THROUGH-BOLTED (STEEL), REFER TO FIGURE 2. IF ANCHORED (CONCRETE), REFER TO FIGURE 3.
- 3) PLOT THE VERTICAL RESTRAINT CAPACITY FROM CURVE #1 (FIGURE 2) OR #4 (FIGURE 3) ON THE VERTICAL AXIS OF FIGURE 1.
- 4) PLOT THE HORIZONTAL RESTRAINT CAPACITY FROM CURVE #3 (FIGURE 2) OR #6 (FIGURE 3) ON THE HORIZONTAL AXIS OF FIGURE 1.
- 5) PLOT THE COMBINED RESTRAINT CAPACITY FROM CURVE #2 (FIGURE 2) OR #5 (FIGURE 3) AT THE POINT ON FIGURE 1 WHERE THE VERTICAL AND HORIZONTAL FORCES BOTH MATCH THIS VALUE.
- 6) CONNECTING THESE POINTS CREATES AN ENVELOPE THAT SHOWS THE RESTRAINT'S CAPACITY WHEN SUBJECTED TO EQUIPMENT SUPPORT AND SEISMIC LOADS SIMULTANEOUSLY.
- 7) FOR THE RESTRAINT TO BE ADEQUATE, ALL WORST CASE SEISMIC LOADS MUST FALL WITHIN THE ENVELOPE.

#### SPECIFICATIONS:

- 3 AXIS RESTRAINT WITH REPLACEABLE NEOPRENE SNUBBING ELEMENTS.
- RESTRAINTS ARE POWDER COATED.
- HOUSINGS MAY BE USED FOR BLOCKING DURING EQUIPMENT ERECTION.
- CAN BE USED WITH OR WITHOUT SPRING COIL.

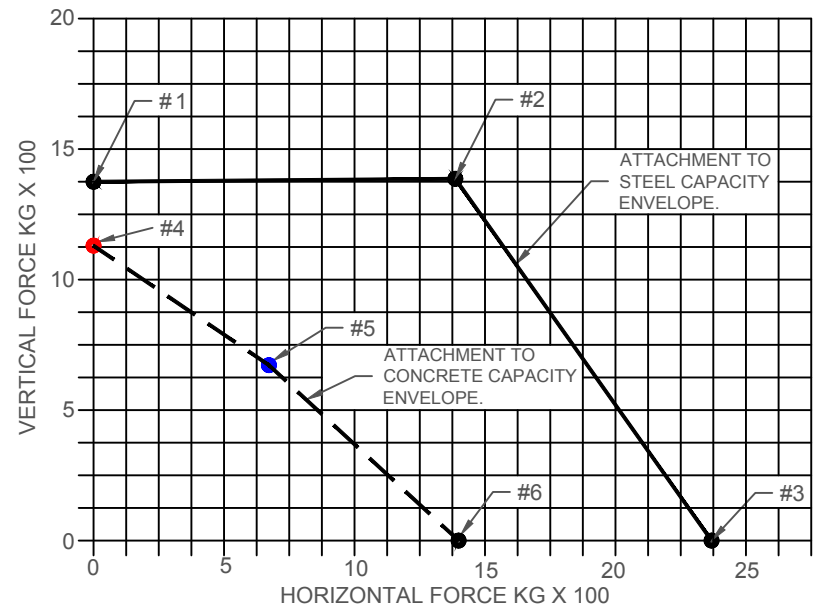
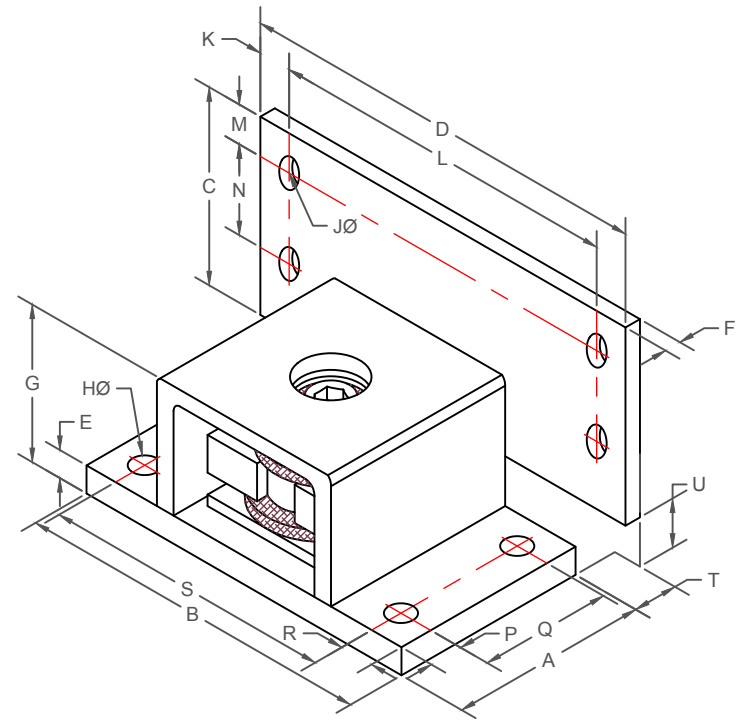

FIGURE 1  
RESTRAINT CAPACITY ENVELOPE