

SH 2" DEFLECTION ISOLATION HANGERS

IP UNITS (INCHES AND POUNDS)

TYPE	H	W	A	DMAX
2-35/220	7.38	3.69	2.25	0.50

STANDARD RATINGS				SPRING COIL		
TYPE	SIZE	LOAD	DEFL.	COLOR	FREE	O.D.
					HT.	
SH	2-35	35	2.00	BLUE	4.13	1.75
SH	2-70	70	2.00	GREEN	4.13	1.75
SH	2-120	120	2.00	GRAY	4.13	1.75
SH	2-220	220	2.00	BROWN	4.13	1.75

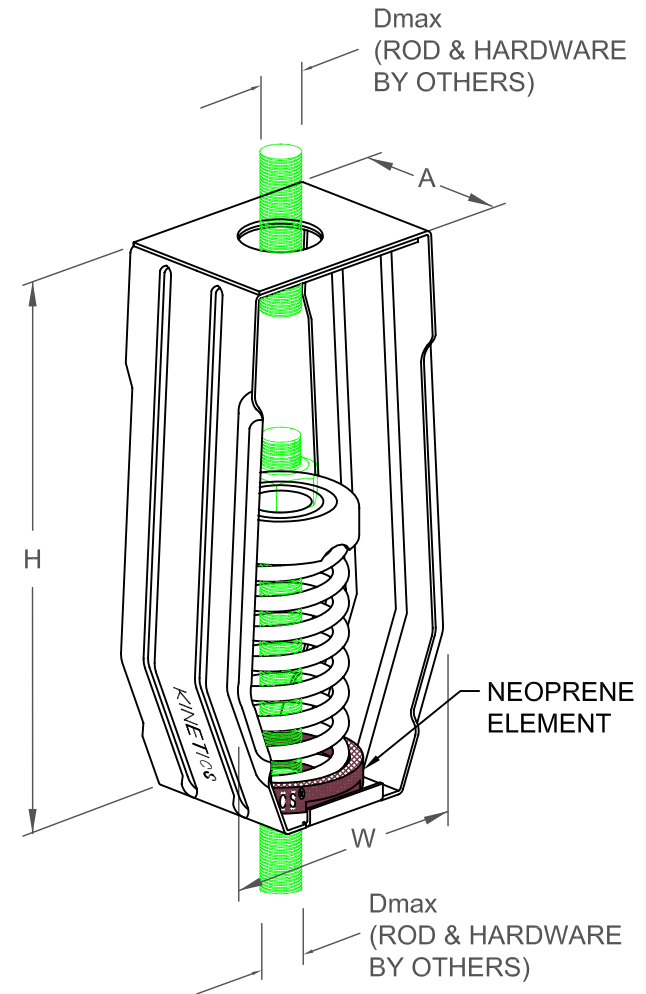

SPECIFICATIONS:

- SPRING ELEMENTS AND BRACKETS ARE POWDER COATED.
- LOAD PLATES ARE BRIGHT ZINC PLATED.
- ISOLATION HANGERS HAVE A TYPICAL OVERLOAD OF 50%.
- ISOLATION HANGERS HAVE A MINIMUM K_x/K_y RATIO OF 1.0.
- SPRING ELEMENTS ARE SAFE AT SOLID LOADING.
- HANGER BRACKETS WILL CARRY (5) TIMES OVERLOAD WITHOUT FAILURE.
- HANGER BRACKETS WILL ALLOW 30° ROD MISALIGNMENT WITHOUT SHORT CIRCUITING.
- HANGERS INCORPORATE "NO SHORT" STEP CAP.



KINETICS NOISE CONTROL, INC
 6300 IRELAN PL,
 DUBLIN, OH 43017 USA
 Ph: 614 889-0480, Fax: 614 889-0540
 www.kineticsnoise.com

Model:
 SH
 2-35/220

By: BB
 Date: 12/07/05
 Revised: /

Drawing No:
 S-03.36-21

SH 51 mm DEFLECTION ISOLATION HANGERS

S-I UNITS (mm AND kg)

TYPE	H	W	A	DMAX
2-35/220	187	94	57	13

STANDARD RATINGS				SPRING COIL		
TYPE	SIZE	LOAD	DEFL.	COLOR	FREE	O.D.
					HT.	
SH	2-35	16	51	BLUE	105	44
SH	2-70	32	51	GREEN	105	44
SH	2-120	54	51	GRAY	105	44
SH	2-220	100	51	BROWN	105	44

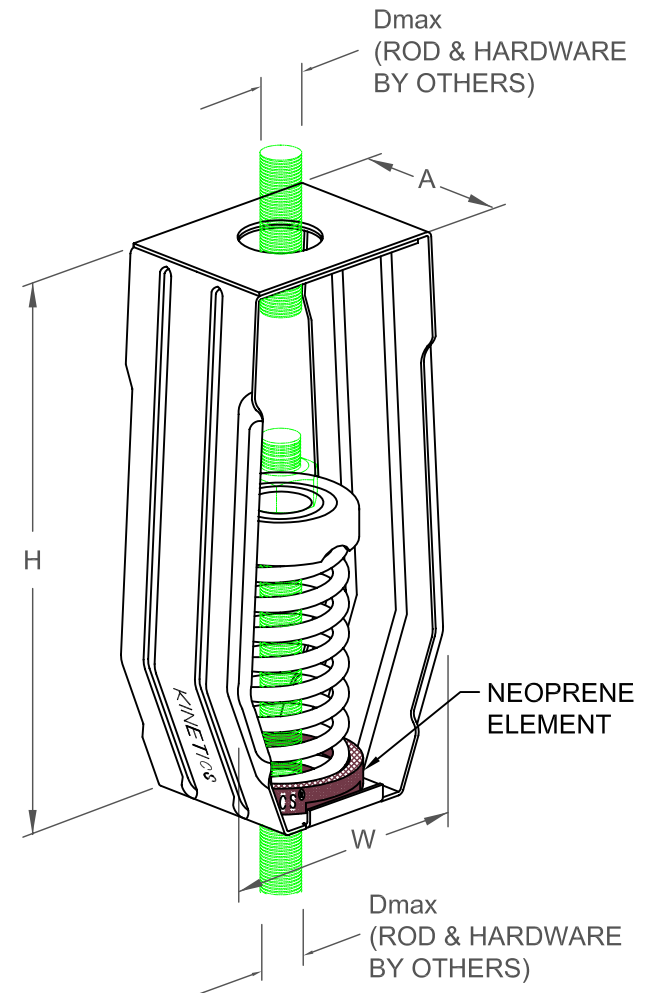

SPECIFICATIONS:

- SPRING ELEMENTS AND BRACKETS ARE POWDER COATED.
- LOAD PLATES ARE BRIGHT ZINC PLATED.
- ISOLATION HANGERS HAVE A TYPICAL OVERLOAD OF 50%.
- ISOLATION HANGERS HAVE A MINIMUM K_x/K_y RATIO OF 1.0.
- SPRING ELEMENTS ARE SAFE AT SOLID LOADING.
- HANGER BRACKETS WILL CARRY (5) TIMES OVERLOAD WITHOUT FAILURE.
- HANGER BRACKETS WILL ALLOW 30° ROD MISALIGNMENT WITHOUT SHORT CIRCUITING.
- HANGERS INCORPORATE "NO SHORT" STEP CAP.



KINETICS NOISE CONTROL, INC
6300 IRELAN PL,
DUBLIN, OH 43017 USA
Ph: 614 889-0480, Fax: 614 889-0540
www.kineticsnoise.com

Model:
SH
2-35/220

By: BB
Date: 12/07/05
Revised: /

Drawing No:
S-03.36-21
METRIC