

# SRH 25 mm DEFLECTION ISOLATION HANGERS

S-I UNITS (mm AND kg)

TYPE	L	H	W	A	Dmax
1-2200/3500	47	241	127	121	22

STANDARD RATINGS				SPRING COIL				INSERT
TYPE	SIZE	LOAD	DEFL.	COLOR		FREE HT.	O.D.	
				OUTER	INNER			COLOR
SRH	1-2200	998	39	ORANGE	GRAY	107	76	PINK
SRH	1-2465	1118	40	BLUE		107	76	PINK
SRH	1-2865	1300	43	BLUE	GRAY	107	76	PINK
SRH	1-3500	1588	46	BLUE	BROWN	107	76	PINK

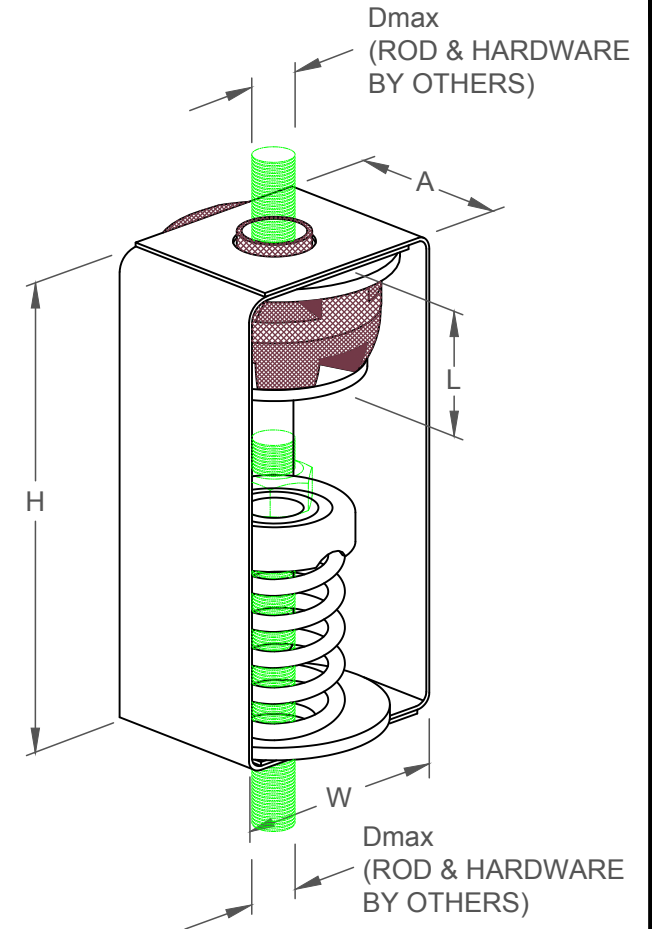

## SPECIFICATIONS:

- SPRING ELEMENTS AND BRACKETS ARE POWDER COATED
- LOAD PLATES ARE BRIGHT ZINC PLATED
- ISOLATION HANGERS HAVE A MINIMUM Kx/Ky RATIO OF 1.0
- SPRING ELEMENTS ARE SAFE AT SOLID LOADING
- HANGER BRACKETS WILL CARRY (5) TIMES OVERLOAD WITHOUT FAILURE
- ISOLATION HANGERS HAVE A TYPICAL OVERLOAD OF 50%
- HANGER BRACKETS WILL ALLOW 30° ROD MISALIGNMENT WITHOUT SHORT CIRCUITING
- "NO SHORT" STEP CAP



KINETICS NOISE CONTROL, INC  
 6300 IRELAN PL,  
 DUBLIN, OH 43017 USA  
 Ph: 614 889-0480, Fax: 614 889-0540  
 www.kineticsnoise.com

Model:  
**SRH**  
 1-2200/3500

By: JMJ  
 Date: 04/15/03  
 Revised: /

Drawing No:  
**S-03.37-14(M)**